

USER MANUAL

Accessory 24E2

Axis Expansion Board

3Ax-603397-xUxx

September 30, 2009



DELTA TAU
Data Systems, Inc.

NEW IDEAS IN MOTION ...

Copyright Information

© 2009 Delta Tau Data Systems, Inc. All rights reserved.

This document is furnished for the customers of Delta Tau Data Systems, Inc. Other uses are unauthorized without written permission of Delta Tau Data Systems, Inc. Information contained in this manual may be updated from time-to-time due to product improvements, etc., and may not conform in every respect to former issues.

To report errors or inconsistencies, call or email:

Delta Tau Data Systems, Inc. Technical Support

Phone: (818) 717-5656

Fax: (818) 998-7807

Email: support@deltatau.com

Website: <http://www.deltatau.com>

Operating Conditions

All Delta Tau Data Systems, Inc. motion controller products, accessories, and amplifiers contain static sensitive components that can be damaged by incorrect handling. When installing or handling Delta Tau Data Systems, Inc. products, avoid contact with highly insulated materials. Only qualified personnel should be allowed to handle this equipment.

In the case of industrial applications, we expect our products to be protected from hazardous or conductive materials and/or environments that could cause harm to the controller by damaging components or causing electrical shorts. When our products are used in an industrial environment, install them into an industrial electrical cabinet or industrial PC to protect them from excessive or corrosive moisture, abnormal ambient temperatures, and conductive materials. If Delta Tau Data Systems, Inc. products are directly exposed to hazardous or conductive materials and/or environments, we cannot guarantee their operation.

REVISION HISTORY

REV.	DESCRIPTION	DATE	CHG	APPVD
1	ADDED UL SEAL TO MANUAL COVER	09/30/09	CP	S. FIERRO

Table of Contents

INTRODUCTION	1
Overview	1
Features	1
Board Configuration.....	1
Acc-24E2 Power Supply Requirements.....	2
E-POINT JUMPER SETTINGS	3
Acc-24E2 Base Board (Channels* 1 & 2)	3
Acc-24E2 Option 1 Board (Channels 3 & 4)	4
HARDWARE SETUP	5
Position Compare Port Driver IC	5
Switch Configuration	5
<i>UMAC Address DIP Switch S1</i>	5
<i>MACRO Station Address DIP Switch S1</i>	5
Acc-24E2 Clock Settings.....	6
Resistor Pack Configuration	6
<i>Differential or Single-Ended Encoder Selection</i>	6
<i>Termination Resistors</i>	7
Acc-24E2 Limit and Flag Wiring.....	7
<i>Connecting Limits/Flags to the Acc-24E2</i>	8
Loss of Encoder Circuit.....	8
<i>Acc-24E2 Encoder Loss Detection with UMAC Turbo CPU</i>	8
<i>Acc-24E2 Encoder Loss Detection with UMAC MACRO CPU</i>	9
CONNECTIONS	11
Mating Connectors	12
<i>Terminal Block Connectors</i>	12
<i>DB15 Connector Option</i>	12
Indicators	12
Overall Wiring Diagram	12
Sample Wiring Diagrams	13
<i>TTL Level Inputs and Outputs</i>	13
<i>Position Limits, Home Flag, and User Flag</i>	14
<i>Acc-24E2 Stepper Motor Outputs (TTL level)</i>	14
Servo IC Configuration I-Variables	14
<i>Servo IC Numbering</i>	14
<i>Servo Channel Numbering</i>	15
<i>Multi-Channel I-Variables</i>	15
<i>Single-Channel I-Variables</i>	16
<i>Encoder Conversion Table I-Variables</i>	16
<i>Motor Addressing I-Variables</i>	16
ULTRALITE/MACRO STATION SETUP	21
Hardware Setup for MACRO Station Use	21
<i>Node-Specific Gate Array MI-Variables</i>	21
Encoder/Timer n Decode Control (MSn,MI910)	21
Flag Capture Control (MSn,MI911-MI913)	22
Output Mode Select (MSn,MI916).....	23
MACRO Station Encoder Conversion Table (MSn,MI120-MI151)	24
<i>Encoder Conversion Table for Acc-24E2 at MACRO Station</i>	24
MLDT FEEDBACK FOR UMAC TURBO AND UMAC MACRO	25
MLDT Hardware Setup of the Acc-24E2	25
MLDT Software Setup of the UMAC Turbo	25
<i>Hardware Setup I-Variables for Servo IC m</i>	25

<i>Conversion Table Processing I-Variables</i>	25
<i>Motor I-Variables</i>	26
<i>Pulse Output Frequency</i>	27
<i>PMAC2/Turbo PMAC2 Conversion Table and Motor I-variables</i>	28
MLDT Feedback for UMAC-MACRO	28
<i>MLDT Software Setup of the UMAC MACRO</i>	28
<i>Station Hardware Setup I-Variables for Servo IC</i>	28
<i>Station Conversion Table Processing I-Variables</i>	29
<i>Station Motor Node I-Variables</i>	29
<i>Power-on Feedback Address for PMAC2 Ultralite</i>	30
<i>MACRO Parallel Absolute Position Setup</i>	31
Connector and Terminal Description.....	33
<i>Direct PWM Amplifier Connector</i>	33
Terminal Block Option for Encoders and EQU	35
<i>Connector TB1 Top – Encoder 1</i>	35
<i>Connector TB2 Top – Encoder 2</i>	35
<i>Connector TB3 Top – EQU Outputs</i>	35
DB15 Connector Option for Encoders and EQU	36
<i>Connector J1 Top - Encoder 1 / EQU</i>	36
<i>Connector J2 Top - Encoder 2 / EQU</i>	36
Flag and User Flag Terminal Block Inputs	36
<i>Connector TB1 Front- Limits 1</i>	36
<i>Connector TB2 Front- Limits 2</i>	37
SCHEMATICS	39

INTRODUCTION

Overview

The Acc-24E2 Axis Expansion Board provides two or four channels of PMAC2-style direct PWM servo interface circuitry for UMAC and Ultralite/MACRO Station controllers. The Acc-24E2 is part of the UMAC family of expansion cards and these accessory cards are designed to plug into an industrial 3U rack system. The information from these accessories is passed directly to either the UMAC or MACRO Station CPU via the high speed UBUS expansion bus. Other axis or feedback interface UBUS accessories include the following:

Acc-14E	Parallel Feedback Inputs (absolute enc. or interferometers)
Acc-24E2	Digital Amplifier Breakout w/ TTL encoder inputs
Acc-24E2A	Analog Amplifier Breakout w/ TTL encoder inputs
Acc-24E2S	Stepper Amplifier Breakout w/ TTL encoder inputs
Acc-28E	16-bit A/D Converter Inputs (up to four per card)
Acc-51E	4096 times interpolator for 1Vpp sinusoidal encoders
Acc-53E	SSI encoder interface (up to 8 channels)

Up to eight Acc-24E2x boards can be connected to one UMAC providing up to 32 additional channels of servo interface circuitry. Because each MACRO Station CPU can service only eight channels of servo data, only two Acc-24E2x boards can be connected to the MACRO-Station. The new MACRO 16-Axis CPU can support four Acc-24E2x cards.

The Acc-24E2 board contains no processor; it has one highly integrated 4-channel PMAC2-style Servo IC with the buffering circuitry and connectors around them. The two-axis Acc-24E2 plugs into the backplane and uses one slot in the Rack. If two more axes are needed, Acc-24E2 Option 1 can be plugged into the Acc-24E2 connectors. The Acc-24E2 with its Option 1 card takes up a total of two slots.

Features

The Acc-24E2 board can be used with any UMAC or MACRO Station CPU interfacing through the UBUS. The Acc-24E2 supports both Direct PWM servo and PFM stepper interfaces:

- Direct digital pulse-width modulated (PWM) phase voltage commands
- Pulse-and-direction commands

Board Configuration

An Acc-24E2 comes standard with one Servo IC providing four servo interface channels, which are brought out on terminal blocks and mini D-Sub connectors. Two of these channels are brought out on the single-board base configuration.

Each channel of servo interface circuitry includes the following:

- Two output command signal sets, configurable as either:
 - One pulse-and-direction
 - Three PWM top-and-bottom pairs
- AB-Quadrature and Index pulse differential/single-ended encoder input
- Nine input flags, two output flags
- Interface to two external serial ADCs, 8 to 18 bits, for current loop feedback

Option 1D: If Option 1D Piggyback Board is ordered, the circuitry and input/output connectors are provided for the third and fourth channels associated with the Servo IC on the main Acc-24E2.

Acc-24E2 Power Supply Requirements

The following table lists the power requirements for the entire Acc-24E2 family of products for the UMAC Turbo and UMAC MACRO. Because of the flexibility of these products, the power requirements for all Acc-24E products are listed.

Product	5V	12V for DACs	-12V for DACs	12V-24V for Flag Circuits
Acc-24E2	700mA	N/A	N/A	
Acc-24E2 opt. 1	200mA	N/A	N/A	
Acc-24E2A	800mA	200mA	200mA	
Acc-24E2 opt. 1A	200mA	200mA	200mA	
Acc-24E2S	600mA	N/A	N/A	

E-POINT JUMPER SETTINGS

Acc-24E2 Base Board (Channels* 1 & 2)

Jumper	Configuration	Description	Default
E1A	1-2	No Jumper for TTL Level input for CHU1 flag Jumper 1-2 for DIR1+ output in Stepper Mode	No jumper
E1B	1-2	No Jumper for TTL Level input for CHV1 flag Jumper 1-2 for DIR1- output in Stepper Mode	No jumper
E1C	1-2	No Jumper for TTL Level input for CHW1 flag Jumper 1-2 for PUL1+ output in Stepper Mode	No jumper
E1D	1-2	No Jumper for TTL Level input for CHT1 flag Jumper 1-2 for PUL1- output in Stepper Mode	No jumper
E2A	1-2	No Jumper for TTL Level input for CHU2 flag Jumper 1-2 for DIR2+ output in Stepper Mode	No jumper
E2B	1-2	No Jumper for TTL Level input for CHV2 flag Jumper 1-2 for DIR2- output in Stepper Mode	No jumper
E2C	1-2	No Jumper for TTL Level input for CHW2 flag Jumper 1-2 for PUL2+ output in Stepper Mode	No jumper
E2D	1-2	No Jumper for TTL Level input for CHT2 flag Jumper 1-2 for PUL2- output in Stepper Mode	No jumper
E5	1-2-3	Jump 1-2 for Turbo 3U CPU and MACRO CPU ** Jump 2-3 for legacy MACRO CPU (before 6/00)	Jump 1-2
E7	1-2	No jumper to not tie D-shell to chassis ground Jump 1-2 to tie J1 D-Shell to chassis ground	No Jumper
E8	1-2	No jumper to not tie D-shell to chassis ground Jump 1-2 to ground J2 D-Shell to Chassis Ground	No Jumper
E10	1-2-3	Connects FC0 to FC3 from J1 PWM AMP1 connectors to U,V,W & T input flags on 1 st Channel Jump 1-2 for high true fault signals Jump 2-3 for low true fault signals	Jump 2-3
E11	1-2-3	Connects FC0 to FC3 from J2 PWM AMP2 connectors to U,V,W & T input flags on 2 nd Channel Jump 1-2 for high true fault signals Jump 2-3 for low true fault signals	Jump 2-3
E13	1-2-3	Jump 1-2 to receive phase and servo clocks Jump 2-3 to transmit phase and servo clocks	Factory set
E111	1-2	No jumper for direct PWM mode axis 1 Jump 1-2 for pulse and direction mode axis 1	No jumper
E112	1-2	No jumper for direct PWM mode axis 2 Jump 1-2 for pulse and direction mode axis 2	No jumper
<p>* The channels refer to the Servo IC associated with the Acc-24E2 base board. For example, an 8-axis application would have two Acc-24E2s with option 1. The first Acc-24E2 would have axes 1-4 and the second Acc-24E2 would contain axes 5-8.</p> <p>** For legacy MACRO Stations (part number 602804-100 thru 602804-104)</p>			

Acc-24E2 Option 1 Board (Channels 3 & 4)

Jumper	Configuration	Description	Default
E1A	1-2	No Jumper for TTL Level input for CHU3 flag Jumper 1-2 for DIR3+ output in Stepper Mode	No jumper
E1B	1-2	No Jumper for TTL Level input for CHV3 flag Jumper 1-2 for DIR3- output in Stepper Mode	No jumper
E1C	1-2	No Jumper for TTL Level input for CHW3 flag Jumper 1-2 for PUL3+ output in Stepper Mode	No jumper
E1D	1-2	No Jumper for TTL Level input for CHT3 flag Jumper 1-2 for PUL3- output in Stepper Mode	No jumper
E2A	1-2	No Jumper for TTL Level input for CHU4 flag Jumper 1-2 for DIR4+ output in Stepper Mode	No jumper
E2B	1-2	No Jumper for TTL Level input for CHV4 flag Jumper 1-2 for DIR4- output in Stepper Mode	No jumper
E2C	1-2	No Jumper for TTL Level input for CHW4 flag Jumper 1-2 for PUL4+ output in Stepper Mode	No jumper
E2D	1-2	No Jumper for TTL Level input for CHT4 flag Jumper 1-2 for PUL4- output in Stepper Mode	No jumper
E7	1-2	No jumper to not tie D-shell to chassis ground Jump 1-2 to tie J1 D-Shell to chassis ground	No Jumper
E8	1-2	No jumper to not tie D-shell to chassis ground Jump 1-2 to ground J2 D-Shell to Chassis Ground	No Jumper
E10	1-2-3	Connects FC0 to FC3 from J1 PWM AMP3 connectors to U,V,W & T input flags on 3 rd Channel Jump 1-2 for high true fault signals Jump 2-3 for low true fault signals	Jump 2-3
E11	1-2-3	Connects FC0 to FC3 from J2 PWM AMP4 connectors to U,V,W & T input flags on 4 th Channel Jump 1-2 for high true fault signals Jump 2-3 for low true fault signals	Jump 2-3
E111	1-2	No jumper for direct PWM mode axis 3 Jump 1-2 for pulse and direction mode axis 3	No jumper
E112	1-2	No jumper for direct PWM mode axis 4 Jump 1-2 for pulse and direction mode axis 4	No jumper

HARDWARE SETUP

Position Compare Port Driver IC

As with the other PMAC controllers, the UMAC has the high speed compare outputs which allows firing an output based on position. This circuit will fire within 100 nsec of reaching the desired position. The position compare output port on Acc-24E2x has driver IC at component U27. This IC gives a fast CMOS driver. This IC gives a fast CMOS driver.

The following table lists the properties of each driver IC:

Part	# of Pins	Max Voltage and Current	Output Type	Max Frequency
DS75451N	8	5V, 10 mA	Totem-Pole (CMOS)	5 MHz

Switch Configuration

UMAC Address DIP Switch S1

S1, S1-3, S1-4 are used to address the Acc-24E2 as shown in the table below.

S1-1	S1-3	S1-4	Board No.	IC No.	I-Var. Range	Base Address
ON	ON	ON	1	2	I7200	\$078200
OFF	ON	ON	2	3	I7300	\$078300
ON	OFF	ON	3	4	I7400	\$079200
OFF	OFF	ON	4	5	I7500	\$079300
ON	ON	OFF	5	6	I7600	\$07A200
OFF	ON	OFF	6	7	I7700	\$07A300
ON	OFF	OFF	7	8	I7800	\$07B200
OFF	OFF	OFF	8	9	I7900	\$07B300

S1-2, S1-5, and S1-6 are used to determine whether the Acc-24E2 is communicating to a Turbo 3U PMAC or a MACRO Station CPU.

S1-2	S1-5	S1-6	Function
ON	ON	ON	3U Turbo PMAC Use

MACRO Station Address DIP Switch S1

S1-1, S1-2, S1-3, S1-4 are used to address the Acc-24E2 as shown in the table below.

S1-1	S1-2*	S1-3	S1-4	Board No.	IC No.	Base Address
ON	ON	OFF	OFF	1	2	\$00C040
OFF	OFF	OFF	OFF	2	3	\$00C060

* Always set to OFF for legacy MACRO Stations (part number 602804-100 through 602804-104)

S1-5 and S1-6 are used to determine whether the Acc-24E2 is communicating to a Turbo 3U PMAC or a MACRO Station CPU.

S1-5	S1-6	Function
OFF	OFF	3U MACRO Station use

Acc-24E2 Clock Settings

The Phase Clock and Servo Clock must be configured on each Acc-24E2x base board. Each system can have only one source for the servo and phase clocks and jumpers must be set appropriately to avoid a timing conflict or a watchdog condition.

Starting in UMAC Turbo firmware version 1.937, the firmware will set the clock settings automatically for the Acc-24E2 cards in the UBUS. To enable this feature, set jumper E13 from 2 to 3 for all of the Acc-24E2s plugged into the UMAC. At re-initialization (either `$$$**` command or power up with E3 jumpered on UMAC), the firmware will know that all of the cards are in the auto configuration setup and will assign the card with the lowest base address setting (usually \$78200) the task of sourcing the clocks by setting variable I19 to the appropriate register. The clocks will be set initially to the factory default servo update cycle and phase clock cycle. For a better understanding of this feature, refer to description of I19 in the Turbo Software Reference Manual.

For UMAC Turbo systems with firmware older than version 1.937, set one of the Acc-24E2s to transmit (E13 set 2-3) the phase and servo clock (usually the card at the lowest base address setting) and the rest of the Acc-24E2s to receive (E13 set 1-2) the phase and servo clocks.

For MACRO systems, the clock select jumper should be set to receive servo and phase clocks. For the Acc-24E2, E13 should be set 1-2.

Resistor Pack Configuration

Differential or Single-Ended Encoder Selection

The differential input signal pairs to the PMAC have user-configurable pull-up/pull-down resistor networks to permit the acceptance of either single-ended or differential signals in one setting, or the detection of lost differential signals in another setting.

- The '+' inputs of each differential pair each have a hard-wired 1 k Ω pull-up resistor to +5V. This cannot be changed.
- The '-' inputs of each differential pair each have a hard-wired 2.2 k Ω resistor to +5V; also each has another 2.2 k Ω resistor as part of a socketed resistor pack that can be configured as a pull-up resistor to +5V, or a pull-down resistor to GND.

If this socketed resistor is configured as a pull-down resistor (the default configuration), the combination of pull-up and pull-down resistors on this line acts as a voltage divider, holding the line at +2.5V in the absence of an external signal. This configuration is required for single-ended inputs using the '+' lines alone; it is desirable for unconnected inputs to prevent the pick-up of spurious noise; it is permissible for differential line-driver inputs.

If this socketed resistor is configured as a pull-up resistor (by reversing the SIP pack in the socket), the two parallel 2.2 k Ω resistors act as a single 1.1 k Ω pull-up resistor, holding the line at +5V in the absence of an external signal. This configuration is required if encoder-loss detection is desired; it is required if complementary open-collector drivers are used; it is permissible for differential line-driver inputs even without encoder loss detection.

If Pin 1 of the resistor pack (marked by a dot on the pack) matches Pin 1 of the socket (marked by a wide white square solder pin on the front side of the board), then the pack is configured as a bank of pull-down resistors. If the pack is reversed in the socket, it is configured as a bank of pull-up resistors.

The following table lists the pull-up/pull-down resistor pack for each input device:

Device	Resistor Pack	Pack Size
Encoder 1	RP22	6-pin
Encoder 2	RP24	6-pin
Encoder 3	RP22	6-pin
Encoder 4	RP24	6-pin

Termination Resistors

The Acc-24E2A provides sockets for termination resistors on differential input pairs coming into the board. As shipped, there are no resistor packs in these sockets. If these signals are brought long distances into the Acc-24E2A board and ringing at signal transitions is a problem, SIP resistor packs may be mounted in these sockets to reduce or eliminate the ringing.

All termination resistor packs have independent resistors (no common connection) with each resistor using two adjacent pins.

Channel Specific Resistor Packs

Channel 1	Channel 2	SIP	Description
RP22	RP24	2.2K Ω	Reverse resistor pack for encoder loss feature (for differential encoders only)
RP23	RP25	220 Ω	Termination resistor to reduce ringing (not installed by default).
RP45	RP46	1K Ω	Install for 5V limits

UBUS Specific Resistor Packs

Resistor Pack	SIP	Description
RP5	220 Ω	Terminator (not installed, only used for non-UBUS)
RP6	2.2K Ω	Pull Down for Old MACRO CPU Pull Up for UMAC Turbo & MACRO

Acc-24E2 Limit and Flag Wiring

The Acc-24E2 allows the use of sinking or sourcing position limits and flags to the controller. The opto-isolator IC used is a PS2705-4NEC-ND quad photo-transistor output type. This IC allows the current to flow from return to flag (sinking) or from flag to return (sourcing).

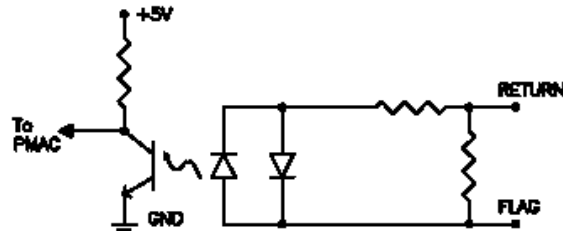

A sample of the positive limit circuit is shown below. The 4.7K resistor packs used will allow 12-24V flag inputs. If 0-5V flags are used, then a 1K Ω resistor pack (RP) can be placed in either RP45 or RP46 (refer to the Resistor Pack Configuration section of this manual). If these resistor packs are not added, all flags (\pm Limits, Home, User, and amplifier fault) will be referenced from 0-5V.

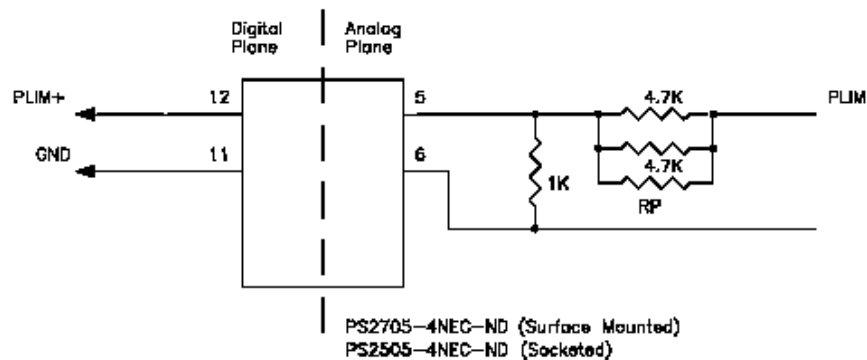

Connecting Limits/Flags to the Acc-24E2

The following diagram illustrates the sinking and sourcing connections to an Acc-24E2. This example uses 12-24V flags.

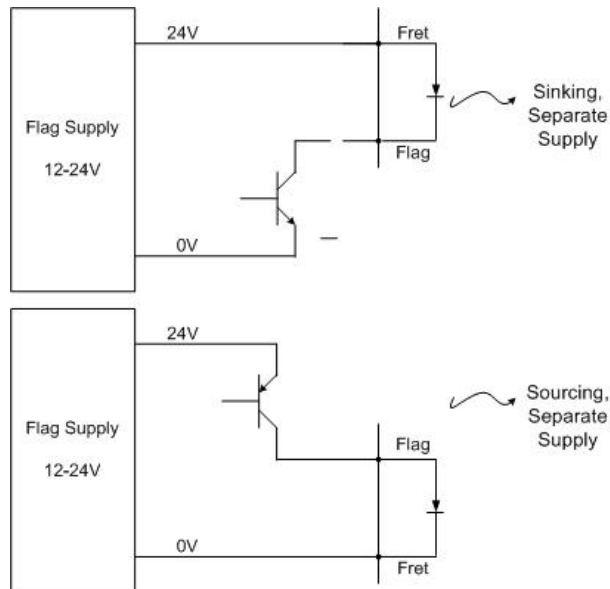

Loss of Encoder Circuit

The encoder-loss detection circuitry works for differential incremental encoders only. In proper operation, the digital states of the complementary inputs for channel (e.g. A and A/) should always be opposite: when one is high, the other is low. If for some reason, such as a cable connection coming undone, one or more of the signal lines is no longer driven, pull-up resistors on the input line pull and hold the signal high.

The encoder-loss detection circuitry uses exclusive-or (XOR) gates on each complementary pair to detect whether the signals are in the same or opposite states. These results are combined to produce a single encoder-loss status bit that the processor can read.

This technique requires that both signal lines of the pair have pull-up resistors. Note that this is not the default configuration of a PMAC as it is shipped. The complementary lines (A/ and B/) are pulled to 2.5V in a voltage-divider configuration as shipped to be able to accept both single-ended and normal differential inputs. This must be changed to a pull-up configuration which involves reversing a socketed resistor pack on the Acc-24E2.

Acc-24E2 Encoder Loss Detection with UMAC Turbo CPU

Channel	Resistor Pack	Status Bit Address (Even-Numbered Servo IC)*	Status Bit Address (Odd-Numbered Servo IC)*	Status Bit Name	Bit Error State
1	RP22	Y:\$07xF08,5	Y:\$B8EC,5	QL_1-	0
2	RP24	Y:\$07xF09,5	Y:\$B8ED,5	QL_2-	0
3	RP22**	Y:\$07xF0A,5	Y:\$B8EE,5	QL_3-	0
4	RP24**	Y:\$07xF0B,5	Y:\$B8EF,5	QL_4-	0

The x digit in this hex address matches the value (8, 9, A, or B) in the fourth digit from the right in the board's own base address (e.g. \$079200). If alternate addressing of Servo ICs is used (e.g. Servo IC 2), add \$20 to these addresses.

**These resistor packs are on the Option 1A piggyback board (if present) of the module, not on the baseboard.

Acc-24E2 Encoder Loss Detection with UMAC MACRO CPU

Channel	Resistor Pack	Status Bit Address (First-Servo IC)*	Status Bit Address (Second Servo IC)*	Status Bit "Name"	Bit Error State
1	RP22	Y:\$B8C8,5	Y:\$B8CC,5	QL_1-	0
2	RP24	Y:\$B8C9,5	Y:\$B8CD,5	QL_2-	0
3	RP22**	Y:\$B8CA,5	Y:\$B8CE,5	QL_3-	0
4	RP24**	Y:\$B8CB,5	Y:\$B8CF,5	QL_4-	0

*First Servo IC has base address \$C040; second Servo IC has base address \$C060
**These resistor packs are on the Option 1A piggyback board (if present) of the module, not on the base board.

CONNECTIONS

This diagram shows the location of connections and jumpers for both the base Acc-24E2 and its Option 1D piggyback board.

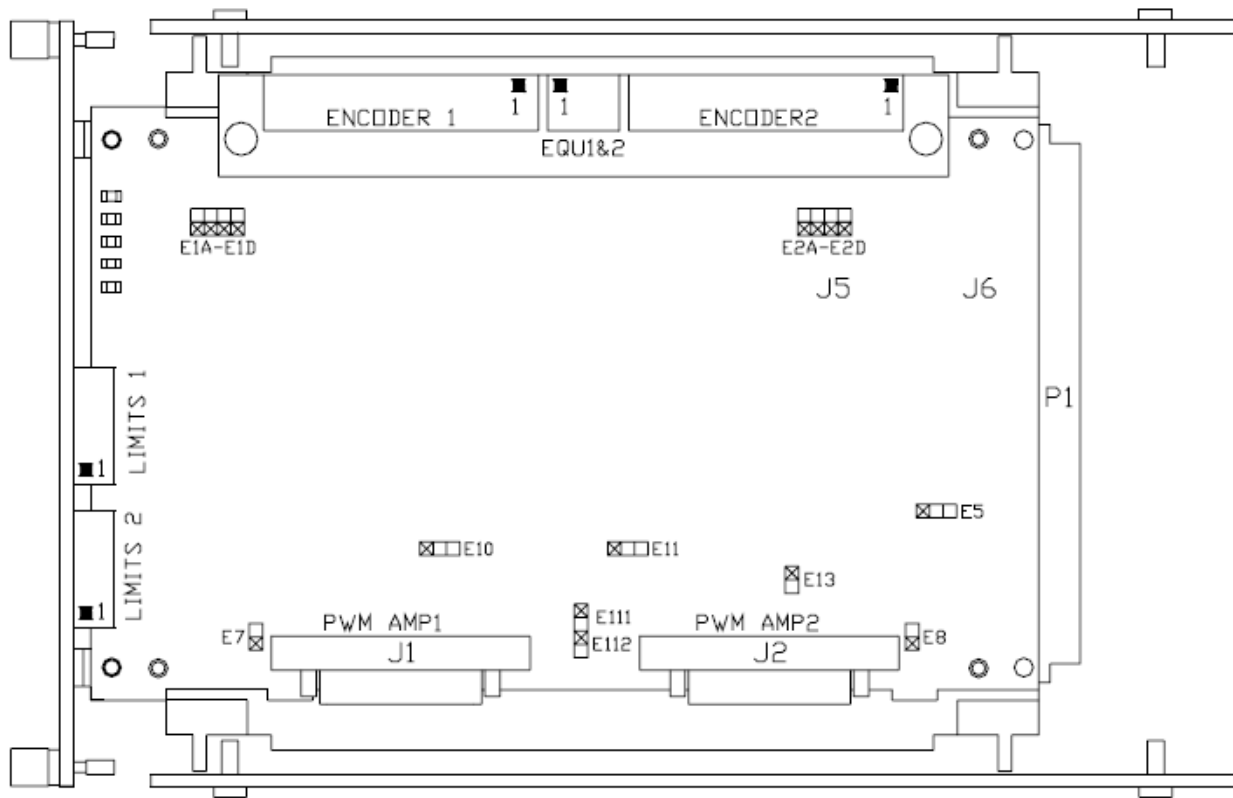

Mating Connectors

Terminal Block Connectors

Name	Manufacturer	Pins	Type	Details
TB1- Top	Phoenix Contact	12	FRONT-MC1,5/12-ST3,81	Encoder 1 Inputs
TB2- Top	Phoenix Contact	12	FRONT-MC1,5/12-ST3,81	Encoder 2 Inputs
TB3- Top	Phoenix Contact	3	FRONT-MC1,5/3-ST3,81	Compare Outputs
TB1- Front	Phoenix Contact	5	FRONT-MC1,5/5-ST3,81	Channel 1 Flags
TB2 Front	Phoenix Contact	5	FRONT-MC1,5/5-ST3,81	Channel 2 Flags

DB15 Connector Option

Name	Manufacturer	Pins	Type	Details
J1- Top	AMP	15	AMP 745072-2	Encoder 1 Inputs and Compare Outputs
J2- Top	AMP	15	AMP 745072-2	Encoder 2 Inputs and Compare Outputs

Indicators

LED	Color	Description
D5	Amber	Amplifier 1 Enabled
D6	Amber	Amplifier 2 enabled
D10	Green	Encoder 1 Power OK
D11	Green	Encoder 2 Power OK
D17	Green	Power Good

Overall Wiring Diagram

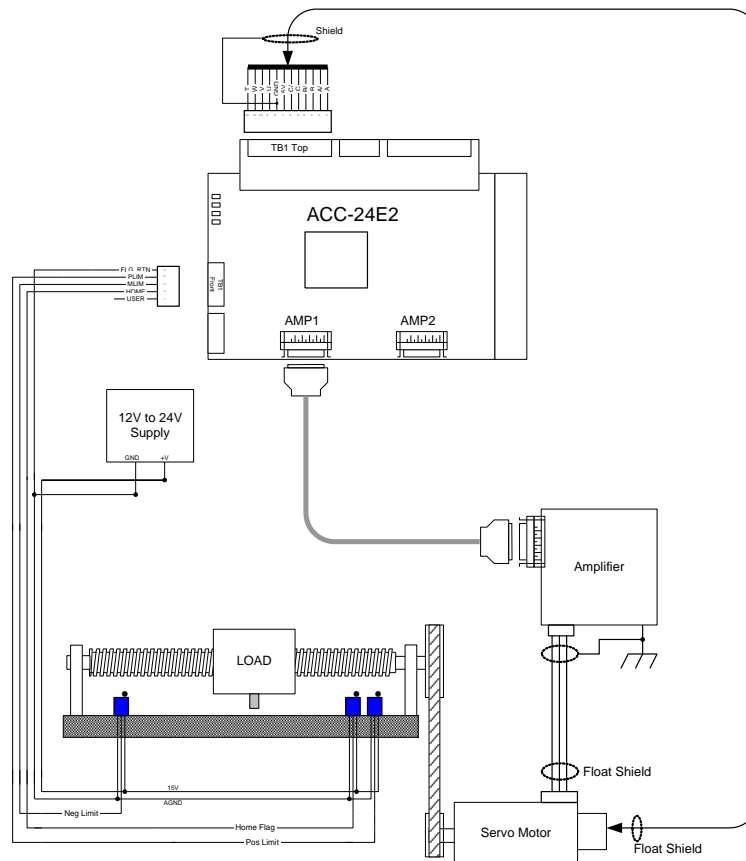

Sample Wiring Diagrams

This section has typical wiring diagrams for the TTL level inputs, flags and limits and PFM outputs.

TTL Level Inputs and Outputs

Quadrature Encoders

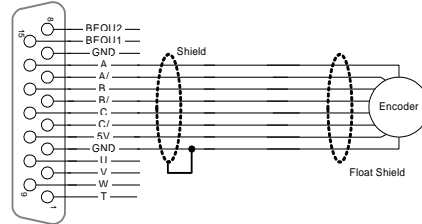
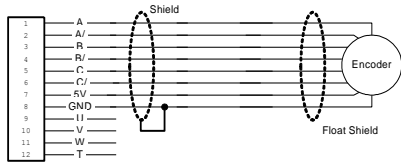
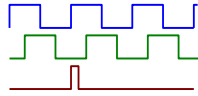

TTL Hall Effect Sensors

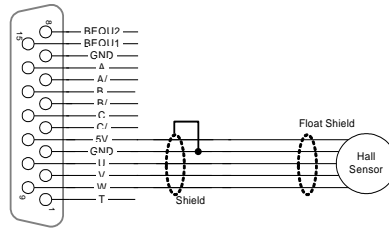
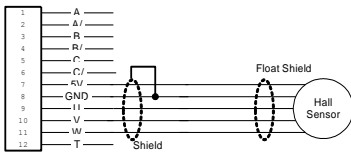
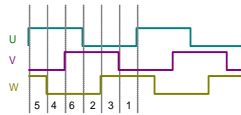

Position Compare Outputs

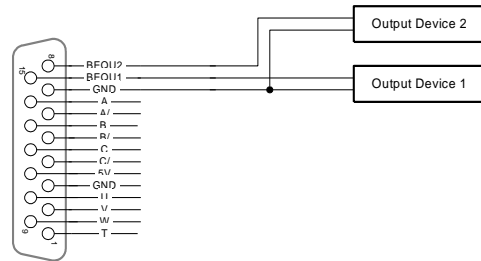
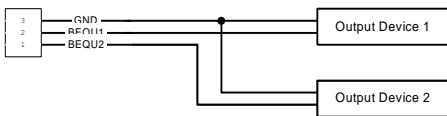
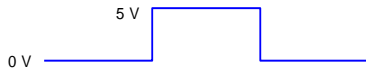

Position Limits, Home Flag, and User Flag

ACC-24E2 Sourcing Flags

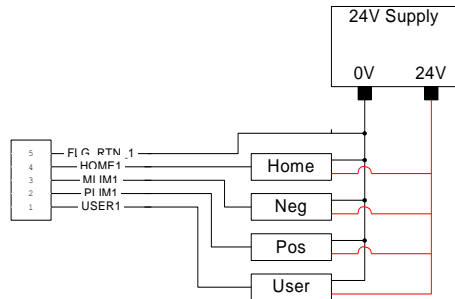

ACC-24E2 Sinking Flags

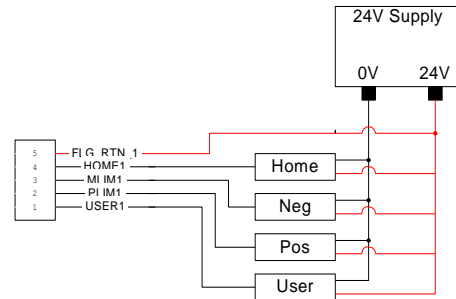

Acc-24E2 Stepper Motor Outputs (TTL level)

ACC-24E2 PFM-Stepper Output

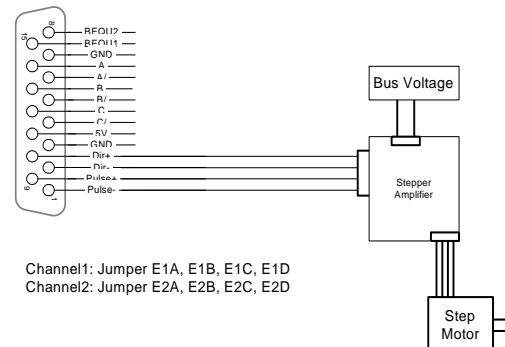
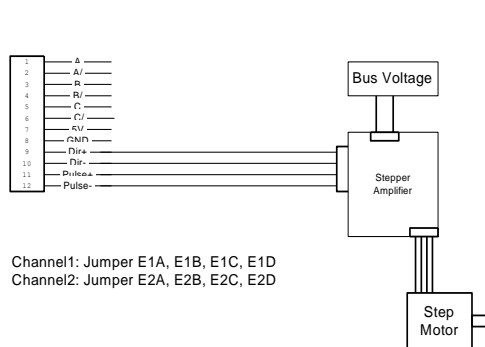

Servo IC Configuration I-Variables

Turbo PMAC I-variables in the range I7000 – I7999 control the configuration of the Servo ICs. The hundreds digit represents the number of the Servo IC (0 to 9) in the system. Servo ICs 0 and 1 are (or can be) on board the Turbo PMAC board itself. Servo ICs 2 through 9 are (or can be) on external devices such as the Acc-24E2.

Servo IC Numbering

The number *m* of the Servo IC on the Acc-24E2 board is dependent on the addressing of the board with DIP switches S1-1, S1-3, and S1-4, which place the board as the first through eight external devices:

- First Acc-24E2 with option 1: Servo IC 2 (channels 1-4)
- Second Acc-24E2 with option 1: Servo IC 3 (channels 5-8)
- Third Acc-24E2 with option 1: Servo IC 4 (channels 9-12)
- Fourth Acc-24E2 with option 1: Servo IC 5 (channels 13-16)
- Fifth Acc-24E2 with option 1: Servo IC 6 (channels 17-20)
- Sixth Acc-24E2 with option 1: Servo IC 7 (channels 21-24)
- Seventh Acc-24E2 with option 1: Servo IC 8 (channels 25-28)
- Eighth Acc-24E2 with option 1: Servo IC 9 (channels 29-32)

The Standard Servo IC on an Acc-24E2 occupies Channels 1-2 on the board, using connectors associated with channels 1 and 2. The Option 1 on an Acc-24E2 occupies Channels 3-4 on the board, using connectors associated with channels 3 and 4.

For example, the Standard Servo IC on the first Acc-24E2 is Servo IC 2 to Turbo PMAC and is configured by variables I7200 – I7299.

Servo Channel Numbering

Each Servo IC has four channels of servo interface circuitry. The tens digit *n* of the I-variable configuring the IC represents the channel number on the IC (*n* = 1 to 4). For example, Channel 1 of the Standard Servo IC on the first Acc-24E2 is configured by variables I7210 – I7219. These channel-specific I-variables are represented generically as I7*mn*0 – I7*mn*9, where *m* represents the Servo IC number (0 – 9) and *n* represents the IC channel number (1-4).

The Channels 1-4 on the Standard Servo IC of an Acc-24E2 correspond to Channels 1-4, respectively, on the Acc-24E2 board itself.

I-variables in the I7000s for which the tens digit is 0 (Channel 0) affect all four channels of the PMAC2-style Servo IC on the Acc-24E2. These multi-channel I-variables are represented generically as I7*m*00 – I7*m*09.

Multi-Channel I-Variables

There are several multi-channel I-variables that must be set up properly for proper operation of the Acc-24E2 in a Turbo PMAC system. The most important are:

I7*m*07: Servo IC *m* Phase/Servo Clock Direction

This variable should be set to 0 the Acc-24E2A generating the clocks (E1 set 2-3) and set to 3 for the Acc-24C2As to receive the clocks (E1 set 1-2).

I7*m*00: Servo IC *m* MaxPhase/PWM Frequency Control

Typically, this will be set to the same value as the variable that controls the system clocks: I7200 on a UMAC Turbo PMAC2, or I6800 on a Turbo PMAC2 Ultralite. If a different PWM frequency is desired then the following constraint should be observed in setting this variable:

$$\frac{2 * PWMFreq(kHz) }{ PhaseFreq } = \{ Integer \}$$

I7*m*01: Servo IC *m* Phase Clock Frequency Control

Even though the IC is receiving an external phase clock (see I7*m*07, above), usually it is best to create the same internal phase clock frequency in the Servo IC. This yields the following constraint:

$$I7m00 * (I7m01 + 1) = I7200 * (I7201 + 1) \quad \{ UMAC Turbo \}$$

$$I7m00 * (I7m01 + 1) = I6800 * (I6801 + 1) \quad \{ Turbo PMAC2 Ultralite \}$$

Solving for I7*m*01, we get

$$I7m01 = \frac{ I7200 * (I7201 + 1) }{ I7m00 } - 1 \quad \{ UMAC Turbo \}$$

$$I7m01 = \frac{ I6800 * (I6801 + 1) }{ I7m00 } - 1 \quad \{ Turbo PMAC2 Ultralite \}$$

If I7*m*00 is the same as I7200 or I6800, I7*m*01 will be the same as I7201 or I6801.

I7*m*02: Servo IC *m* Servo Clock Frequency Control

Even though the IC is receiving an external servo clock (see I7*m*07, above), usually it is best to create the same internal servo clock frequency in the Servo IC. This means that I7*m*02 for the IC should be set the same as I7202 on a UMAC Turbo, or the same as I6802 on a Turbo PMAC2 Ultralite.

I7*m*03: Servo IC *m* Hardware Clock Frequency Control

The hardware clock frequencies for the Servo IC should be set according to the devices attached to it. There is no reason that these frequencies have to be the same between ICs. There is seldom a reason to change this value from the default.

Single-Channel I-Variables

The single-channel setup I-variables for Channel n of Servo IC m work the same on an Acc-24E2 as they do on a Turbo PMAC2 itself. Each Servo IC has four channels n, numbered 1 to 4. For the first (standard) Servo IC on the Acc-24E2, the channel numbers 1 – 4 on the Servo IC are the same as the channel numbers 1 – 4 on the board. The most important variables are:

I7mn0: Servo IC m Channel n Encoder Decode Control

Typically, I7mn0 is set to 3 or 7 for x4 quadrature decode, depending on which way is up. If the channel is used for open-loop stepper drive, I7mn0 is set to 8 to accept internal pulse-and-direction, or to 0 to accept external pulse-and-direction (e.g. from an Acc-8S). It is set to 12 if the channel is used for MLDT feedback.

I7mn2: Servo IC m Channel n Capture Control

I7mn2 determines whether the encoder index channel, an input flag, or both, are used for the capture of the encoder position.

I7mn3: Servo IC m Channel n Capture Flag Select

I7mn3 determines which input flag is used for encoder capture, if one is used.

I7mn6: Servo IC m Channel n Output Mode Select

I7mn6 determines whether the A and B outputs are DAC or PWM, and whether the C output is PFM (pulse-and-direction) or PWM. Typically, it is set to 0, for 3-phase PWM, or to 3 for DACs and PFM.

Encoder Conversion Table I-Variables

To use feedback or master position data from an Acc-24E2, add entries to the encoder conversion table (ECT) using I-variables I8000 – I8191 to address and process this data. The default conversion table in the Turbo PMAC does not contain these entries; it only contains entries for the eight channels on board the Turbo PMAC.

Usually, the position data obtained through an Acc-24E2 board is an incremental encoder feedback, and occasionally an A/D converter feedback from an Acc-28E board or Acc-36E.

The ECT entries for Acc-24E2 incremental encoder channels are shown in the following table:

Servo IC #	Chan. 1	Chan. 2	Chan. 3	Chan. 4	Notes
2	\$m78200	\$m78208	\$m78210	\$m78218	1 st Acc-24E2x Channel n Encoder Set
3	\$m78300	\$m78308	\$m78310	\$m78318	2 nd Acc-24E2x Channel n Encoder Set
4	\$m79200	\$m79208	\$m79210	\$m79218	3 rd Acc-24E2x Channel n Encoder Set
5	\$m79300	\$m79308	\$m79310	\$m79318	4 th Acc-24E2x Channel n Encoder Set
6	\$m7A200	\$m7A208	\$m7A210	\$m7A218	5 th Acc-24E2x Channel n Encoder Set
7	\$m7A300	\$m7A308	\$m7A310	\$m7A318	6 th Acc-24E2x Channel n Encoder Set
8	\$m7B200	\$m7B208	\$m7B210	\$m7B218	7 th Acc-24E2x Channel n Encoder Set
9	\$m7B300	\$m7B308	\$m7B310	\$m7B318	8 th Acc-24E2x Channel n Encoder Set

The first hexadecimal digit in the entry, represented by m in the table, is a 0 for the most common 1/T timer-based extension of digital incremental encoders; it is an 8 for the parallel-data extension of analog incremental encoders; it is a C for no extension of an incremental encoder.

Motor Addressing I-Variables

For a Turbo PMAC motor to use the servo interface circuitry of the Acc-24E2, several of the addressing I-variables for the motor must contain the addresses of registers in the Acc-24E2, or the addresses of encoder conversion table registers containing data processed from the Acc-24E2. These I-variables can include:

Ixx02: Motor xx Command Output Address

Ixx02 tells Turbo PMAC where to write its command outputs for Motor xx. If Acc-24E2 is to create the command signals, Ixx02 must contain the address of the register.

The following table shows the address of the A output register for each channel of each Acc-24E2. These addresses can be used for single analog outputs, double analog outputs, or direct PWM outputs.

Servo IC #	Chan. 1	Chan. 2	Chan. 3	Chan. 4	Notes
2	\$078202	\$07820A	\$078212	\$07821A	1 st Acc-24E2x Channel n DAC/PWMnA
3	\$078302	\$07830A	\$078312	\$07831A	2 nd Acc-24E2x Channel n DAC/PWMnA
4	\$079202	\$07920A	\$079212	\$07921A	3 rd Acc-24E2x Channel n DAC/PWMnA
5	\$079302	\$07930A	\$079312	\$07931A	4 th Acc-24E2x Channel n DAC/PWMnA
6	\$07A202	\$07A20A	\$07A212	\$07A21A	5 th Acc-24E2x Channel n DAC/PWMnA
7	\$07A302	\$07A30A	\$07A312	\$07A31A	6 th Acc-24E2x Channel n DAC/PWMnA
8	\$07B202	\$07B20A	\$07B212	\$07B21A	7 th Acc-24E2x Channel n DAC/PWMnA
9	\$07B302	\$07B30A	\$07B312	\$07B31A	8 th Acc-24E2x Channel n DAC/PWMnA

If the C output register for a given Acc-24E2 and channel is used (primarily for pulse and direction output), simply add 2 to the address shown in the above table. For example, on the first Acc-24E2, output register 1C is at address \$078204.

Ixx03: Motor xx Position-Loop Feedback Address

Ixx04: Motor xx Velocity-Loop Feedback Address

Ixx05: Motor xx Master Position Address

Usually, the Ixx03, Ixx04, and Ixx05 variables contain the address of a processed position value in the encoder conversion table, even when the raw data comes from the Acc-24E2. The first line of the encoder conversion table is at address \$003501; the last line is at address \$0035C0.

Ixx10: Motor xx Power-On Position Address

Ixx10 tells the Turbo PMAC where to read absolute power-on position, if any. Typically, the only times Ixx10 will contain the address of an Acc-24E2 register is if the position is obtained from an A/D converter on an Acc-28B connected through the Acc-24E2, or if it is obtained from an MLDT (e.g. Temposonics™) sensor excited directly from an Acc-24E2.

The following table shows the possible values of Ixx10 for MLDT timer registers:

Ixx10 for Acc-24E2 MLDT Timer Registers (Ixx95=\$170000)

Servo IC #	Chan. 1	Chan. 2	Chan. 3	Chan. 4	Notes
2	\$078200	\$078208	\$078210	\$078218	1 st Acc-24E2x Channel n Timer
3	\$078300	\$078308	\$078310	\$078318	2 nd Acc-24E2x Channel n Timer
4	\$079200	\$079208	\$079210	\$079218	3 rd Acc-24E2x Channel n Timer
5	\$079300	\$079308	\$079310	\$079318	4 th Acc-24E2x Channel n Timer
6	\$07A200	\$07A208	\$07A210	\$07A218	5 th Acc-24E2x Channel n Timer
7	\$07A300	\$07A308	\$07A310	\$07A318	6 th Acc-24E2x Channel n Timer
8	\$07B200	\$07B208	\$07B210	\$07B218	7 th Acc-24E2x Channel n Timer
9	\$07B300	\$07B308	\$07B310	\$07B318	8 th Acc-24E2x Channel n Timer

Ixx24: Motor xx Flag Mode

Ixx24 defines how to read and use the flags for Motor xx that are in the register specified by Ixx25. Ixx24 is a set of independent control bits. There are two bits that must be set correctly to use a flag set on an Acc-24E2.

Bit 0 of Ixx24 must be set to 1 to tell the Turbo PMAC that this flag set is in a Type 1 PMAC2-style Servo IC. Bit 18 of Ixx24 must be set to 0 to tell the Turbo PMAC that this flag set is not transmitted over a MACRO ring. Other bits of Ixx24 may be set as desired for a particular application.

Ixx25: Motor xx Flag Address

Ixx25 tells Turbo PMAC where to access its flag data for Motor xx. If Acc-24E2 is interfaced to the flags, Ixx25 must contain the address of the flag register in Acc-24E2.

The following table shows the address of the flag register for each channel of each Acc-24E2.

Servo IC #	Chan. 1	Chan. 2	Chan. 3	Chan. 4	Notes
2	\$078200	\$078208	\$078210	\$078218	1 st Acc-24E2x Channel n Flag Set
3	\$078300	\$078308	\$078310	\$078318	2 nd Acc-24E2x Channel n Flag Set
4	\$079200	\$079208	\$079210	\$079218	3 rd Acc-24E2x Channel n Flag Set
5	\$079300	\$079308	\$079310	\$079318	4 th Acc-24E2x Channel n Flag Set
6	\$07A200	\$07A208	\$07A210	\$07A218	5 th Acc-24E2x Channel n Flag Set
7	\$07A300	\$07A308	\$07A310	\$07A318	6 th Acc-24E2x Channel n Flag Set
8	\$07B200	\$07B208	\$07B210	\$07B218	7 th Acc-24E2x Channel n Flag Set
9	\$07B300	\$07B308	\$07B310	\$07B318	8 th Acc-24E2x Channel n Flag Set

Ixx81: Motor xx Power-On Phase Position Address

Ixx81 tells Turbo PMAC2 where to read absolute power-on position for motor phase commutation, if any. Typically, it will contain the address of an Acc-24E2 register for only two types of absolute phasing sensors: hall-effect commutation sensors (or their optical equivalents) connected to the U, V, and W input flags on an Acc-24E2 channel, or the encoder counter filled by simulated quadrature from a Yaskawa absolute encoder connected to the Acc-24E2 through an Acc-57E board.

The following table contains the possible settings of Ixx81 to read the encoder counters for Yaskawa absolute encoders:

Turbo PMAC Ixx81 Acc-24E2 Encoder Register Settings (Ix91=\$480000 - \$580000)

Servo IC #	Chan. 1	Chan. 2	Chan. 3	Chan. 4	Notes
2	\$078201	\$078209	\$078211	\$078219	1 st Acc-24E2x Channel n Encoder Reg.
3	\$078301	\$078309	\$078311	\$078319	2 nd Acc-24E2x Channel n Encoder Reg.
4	\$079201	\$079209	\$079211	\$079219	3 rd Acc-24E2x Channel n Encoder Reg.
5	\$079301	\$079309	\$079311	\$079319	4 th Acc-24E2x Channel n Encoder Reg.
6	\$07A201	\$07A209	\$07A211	\$07A219	5 th Acc-24E2x Channel n Encoder Reg.
7	\$07A301	\$07A309	\$07A311	\$07A319	6 th Acc-24E2x Channel n Encoder Reg.
8	\$07B201	\$07B209	\$07B211	\$07B219	7 th Acc-24E2x Channel n Encoder Reg.
9	\$07B301	\$07B309	\$07B311	\$07B319	8 th Acc-24E2x Channel n Encoder Reg.

Ixx82: Motor xx Current Feedback Address

Ixx82 tells Turbo PMAC where to get its current-loop feedback every phase update cycle. If Ixx82 is set to 0, Turbo PMAC does not perform current-loop calculations for Motor xx.

The following table shows the possible values of Ixx82 for Acc-24E2 ADC register pairs:

Turbo PMAC Ixx82 Acc-24E2 ADC Register Settings

ADC Register Channel #	1 st Acc-24E2	2 nd Acc-24E2	3 rd Acc-24E2	4 th Acc-24E2
Channel 1	\$078206	\$079206	\$07A206	\$07B206
Channel 2	\$07820E	\$07920E	\$07A20E	\$07B20E
Channel 3	\$078216	\$079216	\$07A216	\$07B216
Channel 4	\$07821E	\$07921E	\$07A21E	\$07B21E
Channel 5	\$078306	\$079306	\$07A306	\$07B306
Channel 6	\$07830E	\$07930E	\$07A30E	\$07B30E
Channel 7	\$078316	\$079316	\$07A316	\$07B316
Channel 8	\$07831E	\$07931E	\$07A31E	\$07B31E

Ixx83: Motor xx Phase Position Address

Ixx83 tells Turbo PMAC where to get its commutation position feedback every phase update cycle. Usually, this contains the address of an encoder phase position register.

The following table shows the possible values of Ixx83 for Acc-24E2 encoder phase position registers:

Turbo PMAC Ixx83 Acc-24E2 Encoder Register Settings

Servo IC #	Chan. 1	Chan. 2	Chan. 3	Chan. 4	Notes
2	\$078201	\$078209	\$078211	\$078219	1 st Acc-24E2x Channel n Encoder Reg.
3	\$078301	\$078309	\$078311	\$078319	2 nd Acc-24E2x Channel n Encoder Reg.
4	\$079201	\$079209	\$079211	\$079219	3 rd Acc-24E2x Channel n Encoder Reg.
5	\$079301	\$079309	\$079311	\$079319	4 th Acc-24E2x Channel n Encoder Reg.
6	\$07A201	\$07A209	\$07A211	\$07A219	5 th Acc-24E2x Channel n Encoder Reg.
7	\$07A301	\$07A309	\$07A311	\$07A319	6 th Acc-24E2x Channel n Encoder Reg.
8	\$07B201	\$07B209	\$07B211	\$07B219	7 th Acc-24E2x Channel n Encoder Reg.
9	\$07B301	\$07B309	\$07B311	\$07B319	8 th Acc-24E2x Channel n Encoder Reg.

ULTRALITE/MACRO STATION SETUP

The Acc-24E2 family of JEXP accessories can also be used with MACRO Station to breakout the standard amplifier, flag, and encoder signals. The gate arrays on the Acc-24E2 family of accessories are located in the traditional channel 9-16 locations of the PMAC2 memory map.

Note:

In order for the MACRO Station to setup its output and input channels automatically, MACRO Station firmware 1.114 or greater must be used.

Currently there are three types of Acc-24Es to be used with the MACRO Station:

Acc-24E2	Direct PWM commutation outputs
Acc-24E2A	±10V Outputs for torque, velocity and sinusoidal input amplifiers
Acc-24E2S	Dedicated 4-channel stepper interface card

MACRO Station Gate Array Locations for Acc-24E2

Chan #	9	10	11	12	13	14	15	16
Hex	[\$C040]	[\$C048]	[\$C050]	[\$C058]	[\$C060]	[\$C068]	[\$C070]	[\$C078]

Hardware Setup for MACRO Station Use

A few hardware selections must be set in order to use this accessory with the MACRO Station:

E5	Jumper 1-2 for MACRO Communications
E13	Jumper 1-2 for Clock Settings
SW1	SW1-1 and SW1-2 ON for \$C040, SW1-1 and SW1-2 OFF for \$C060
SW1	SW1-3 through SW1-6 set to off

The Delta Tau Setup software for either the standard PMAC2 Ultralite or Turbo PMAC2 Ultralite will setup all of the important MI-Variables at the MACRO Station.

Node-Specific Gate Array MI-Variables

MI-variables MI910 through MI919 on the MACRO station control the hardware setup of the hardware interface channel on the station associated a MACRO node. The matching of hardware interface channels to MACRO nodes is determined by the setting of the SW1 rotary switch on the CPU/Interface Board of the MACRO station.

These variables are accessed using the MS station auxiliary read and write commands. The number immediately after the MS specifies the node number, and therefore the channel number mapped to that node by the SW1 setting.

Encoder/Timer n Decode Control (MSn,MI910)

MI910 controls how the input signal for the encoder mapped to the specified node is decoded into counts. As such, this defines the sign and magnitude of a count. The following settings may be used to decode an input signal.

- 0: Pulse and direction CW
- 1: x1 quadrature decode CW
- 2: x2 quadrature decode CW
- 3: x4 quadrature decode CW
- 4: Pulse and direction CCW
- 5: x1 quadrature decode CCW
- 6: x2 quadrature decode CCW
- 7: x4 quadrature decode CCW

- 8: Internal pulse and direction
- 9: Not used
- 10: Not used
- 11: Not used
- 12: MLDT pulse timer control
(internal pulse resets timer; external pulse latches timer)
- 13: Not used
- 14: Not used
- 15: Not used

In any of the quadrature decode modes, PMAC is expecting two input waveforms on CHAn and CHBn, each with approximately 50% duty cycle, and approximately one-quarter of a cycle out of phase with each other. Times-one (x1) decode provides one count per cycle; x2 provides two counts per cycle; and x4 provides four counts per cycle. Select x4 decode to get maximum resolution.

The clockwise (CW) and counterclockwise (CCW) options simply control which direction counts up. If it is the wrong direction sense, simply change to the other option (e.g., from 7 to 3 or vice versa).

Warning:

If the direction sense of an encoder with a properly working servo is changed without also changing the direction sense of the output, destabilizing positive feedback to the servo and a dangerous runaway condition will result.

In the pulse-and-direction decode modes, PMAC is expecting the pulse train on CHAn, and the direction (sign) signal on CHBn. If the signal is unidirectional, the CHBn line can be allowed to pull up to a high state, or it can be hardwired to a high or low state.

If MI910 is set to 8, the decoder inputs the pulse and direction signal generated by Channel n's pulse frequency modulator (PFM) output circuitry. This permits the Compact MACRO Station to create a phantom closed loop when driving an open-loop stepper system. No jumpers or cables are needed to do this; the connection is entirely within the ASIC. The counter polarity matches the PFM output polarity automatically.

If MI910 is set to 12, the timer circuitry is set up to read magnetostrictive linear displacement transducers (MLDTs) such as Temposonics™. In this mode, the timer is cleared when the PFM circuitry sends out the excitation pulse to the sensor on PULSEn, and it is latched into the memory-mapped register when the excitation pulse is received on CHAn.

Flag Capture Control (MSn,MI911-MI913)

The flag capture registers must also be setup at the MACRO Station for proper homing, encoder capturing, and setting compare outputs.

MI911 determines which encoder input the position compare circuitry for the machine interface channel mapped to the specified node uses.

MSn,MI911=0	Use channel n encoder counter for position compare function
MSn,MI911=1	Use first encoder counter on IC (encoder 1 for channels 1 to 4; encoder 5 for channels 5 to 8) for position compare function

When MI911 is set to 0, the channel's position compare register is tied to the channel's own encoder counter, and the position compare signal appears only on the EQU_n output.

When MI911 is set to 1, the channel's position compare register is tied to the first encoder counter on the ASIC (Encoder 1 for channels 1-4, Encoder 5 for channels 5-8, or Encoder 9 for channels 9-10) and the position compare signal appears both on EQU_n, and combined into the EQU output for the first channel on the IC (EQU1 or EQU5); executed as a logical OR.

MI911 for the first channel on an ASIC performs no effective function, so is always 1. It cannot be set to 0.

MI912 determines which signal or combination of signals, and which polarity, triggers a position capture of the counter for the encoder mapped to the specified node. If a flag input (home, limit, or user) is used, MI913 for the node determines which flag. Proper setup of this variable is essential for a successful home search, which depends on the position-capture function. The following settings may be used:

- 0: Capture under software control (armed)
- 1: Capture on Index (CHC_n) high
- 2: Capture on Flag high
- 3: Capture on (Index high AND Flag high)
- 4: Capture under software control (latched)
- 5: Capture on Index (CHC_n) low
- 6: Capture on Flag high
- 7: Capture on (Index low AND Flag high)
- 8: Capture under software control (armed)
- 9: Capture on Index (CHC_n) high
- 10: Capture on Flag low
- 11: Capture on (Index high AND Flag low)
- 12: Capture under software control (latched)
- 13: Capture on Index (CHC_n) low
- 14: Capture on Flag low
- 15: Capture on (Index low AND Flag low)

The trigger is armed when the position capture register is read. After this, as soon as the Compact MACRO Station sees that the specified input lines are in the specified states, the trigger will occur – it is level-trigger, not edge-triggered.

MI913 parameter determines which of the Flag inputs will be used for position capture (if one is used, see MI912):

- 0: HMFL_n (Home Flag n)
- 1: PLIM_n (Positive End Limit Flag n)
- 2: MLIM_n (Negative End Limit Flag n)
- 3: USER_n (User Flag n)

Typically, this parameter is set to 0 or 3, because in actual use, the LIM_n flags create other effects that usually interfere with what is trying to be accomplished by the position capture. To capture on the LIM_n flags, disable the normal functions with Ix25, or use a channel n where none of the flags is used for the normal axis functions

Output Mode Select (MS_n,MI916)

The Acc-24E2 family of boards can be used for multiple mode outputs. At the MACRO Station, the output mode on MACRO Station variable MS_n,MI916 must be set up. The table below shows the output modes available for each of the Acc-24E2 boards. The output mode select will be set up automatically if using either the P2Setup or the Turbo Setup programs.

Board	Direct PWM Mode	DAC Mode	Pulse and Direct
Acc-24E2	Yes	No	Yes
Acc-24E2A	No	Yes	Yes
Acc-24E2S	No	No	Yes

The PMAC2 Style outputs allow the PMAC to control up to three individual output channels based on the mode. These outputs are described as output A, output B, and output C.

MSn, MI916	Output Description	Typical Use
0	A, B, and C are PWM	Direct PWM Mode Only
1	A and B are DAC C is PWM	±10V Outputs for torque, velocity and sinusoidal input amplifier
2	A and B are PWM C is PFM	Stepper Systems
3	A and B are DAC C is PFM	±10V Outputs with MLDT Feedback
The default output at the MACRO Station is PWM (MSn,I916=0).		

MACRO Station Encoder Conversion Table (MSn,MI120-MI151)

At power-up, the MACRO Station will set up all of the key memory locations and MI-Variables based on the SW1 connector and firmware of the MACRO Station automatically. The key variables set up at power-up are the encoder conversion table, servo output registers, and flag input registers.

Encoder Conversion Table for Acc-24E2 at MACRO Station

```
MS0,MI120=$00C040      ;output at X:$0010 at MACRO Station (encoder 1)
MS0,MI121=$00C048      ;output at X:$0011 at MACRO Station (encoder 2)
MS0,MI122=$00C050      ;output at X:$0012 at MACRO Station (encoder 3)
MS0,MI123=$00C058      ;output at X:$0013 at MACRO Station (encoder 4)
MS0,MI120=$00C060      ;output at X:$0014 at MACRO Station (encoder 5)
MS0,MI121=$00C068      ;output at X:$0015 at MACRO Station (encoder 6)
MS0,MI122=$00C070      ;output at X:$0016 at MACRO Station (encoder 7)
MS0,MI123=$00C078      ;output at X:$0017 at MACRO Station (encoder 8)
```

MLDT FEEDBACK FOR UMAC TURBO AND UMAC MACRO

The Acc-24E2 can provide direct interface to magnetostrictive linear displacement transducers (MLDTs) through its encoder connectors. This interface is for MLDTs with an external excitation format (often called RS-422 format because of the signal levels). The Acc-24E2 provides the excitation pulse, and receives the echo pulse, both with RS-422 signal formats.

This section provides basic information for using MLDTs with the Acc-24E2. More information can be found in the User Manuals for the Turbo PMAC or the MACRO Station.

MLDT Hardware Setup of the Acc-24E2

The Acc-24E2 must be set up to output the differential pulse on what is normally the T and W input flags on the encoder connector. This is done by putting jumpers on E-points E1C and E1D for the first channel on the board, or E2C and E2D for the second channel on the board. These jumpers are OFF by default.

The PULSE+ (high during the pulse) and PULSE- (low during the pulse) outputs from the encoder connector are connected to the differential pulse inputs on the MLDT. The echo pulse differential outputs from the MLDT are connected to the CHA+ and CHA- input pins on the same encoder connector.

If the MLDT uses RPM format, in which there is a brief start echo pulse, and a brief stop echo pulse, the “+” output from the MLDT should be connected to the CHA+ input on the Acc-24E2, and the “-” output should be connected to the CHA- input.

If the MLDT uses DPM format, in which there is a single long echo pulse, with the delay to the trailing edge measuring the position, the “+” output from the MLDT should be connected to the CHA- input on the Acc-24E2, and the “-” output should be connected to the CHA+ input.

MLDT Software Setup of the UMAC Turbo

When the Acc-24E2 is used for MLDT feedback in a UMAC Turbo system, a few I-variables must be set up properly.

Hardware Setup I-Variables for Servo IC m

I7m03 (PFM Clock Frequency)

Usually, the clock frequency driving the pulse-generation circuitry for all channels on Servo IC m can be left at its default value of 9.83 MHz (0.102 μ sec). I7m03 also controls other clock signals, has a default value of 2258, and rarely needs to be changed.

I7m04 (PFM Pulse Width)

The pulse width, set by I7m04 in units of PFM clock cycles must be set long enough for the MLDT to see, and long enough to contain the rising edge of the RPM start echo pulse, or the rising edge of the single DPM echo pulse. For example, if this edge can come up to 2 μ sec after the start of the excitation pulse and the PMAC clock cycle is at its default of about 0.1 μ sec, then I7m04 must be set at least to 20.

I7mn6 (Output Format Select)

For Servo IC m Channel n to be used for MLDT feedback, I7mn6 must be set to 1 or 3 for the C sub-channel to be used for PFM-format output. On an Acc-24E2A, I7mn6 must then be set to 3 for the A and B sub-channels to be used for DAC-format output.

I7mn0 (MLDT Feedback Select)

For Servo IC m Channel n to be used for MLDT feedback, I7mn0 must be set to 12. In this mode, the pulse timer is cleared on the output pulse, and latched on the echo pulse, counting in between at 117.96 MHz.

Conversion Table Processing I-Variables

The pulse timer for Servo IC m Channel n holds a number proportional to the time and therefore the position. This must be processed in the conversion table before it can be used by the servo loop. It is best to use the filtered parallel data conversion, a 3-line entry in the table (three consecutive I-variables).

Line 1 (Method and Address): This 24-bit value (6 hex digits) should begin with a 3 (filtered parallel data) followed by the address of the timer register. The possible values for this line are shown in the following table:

Encoder Conversion Table Parallel Filtered Data Format First Line for Acc-24E2A Boards with Servo IC m Channel n

Acc-24 #	Servo IC #	Channel 1	Channel 2	Channel 3	Channel 4
1A	2	\$378200	\$378208	\$378210	\$378218
1B	3	\$378300	\$378308	\$378310	\$378318
2A	4	\$379200	\$379208	\$379210	\$379218
2B	5	\$379300	\$379308	\$379310	\$379318
3A	6	\$37A200	\$37A208	\$37A210	\$37A218
3B	7	\$37A300	\$37A308	\$37A310	\$37A318
4A	8	\$37B200	\$37B208	\$37B210	\$37B218
4B	9	\$37B300	\$37B308	\$37B310	\$37B318

Line 2 (Width and Start): This 24-bit value should be set to \$013000 to specify the use of 19 bits (\$013) starting at bit 0.

Line 3 (Max Change): This 24-bit value should be set to a value slightly greater than the maximum true velocity ever expected, expressed in timer LSBs per servo cycle. With a typical MLDT, the 117.96 MHz timer LSB represents 0.024 mm (0.00094 inches); the default servo cycle is 0.442 msec.

The result of this conversion is in the X-register of the third line. Any functions using this value should address this register. For example, if this were the first entry in the table, which starts at \$003501, the result would be in X:\$003503.

Motor I-Variables

Ixx03 (Position Loop Feedback Address)

To use the result of the conversion table for position-loop feedback for Motor xx, Ixx03 should contain the address of the result register in the conversion table - \$003503 in the above example.

Ixx04 (Velocity Loop Feedback Address)

To use the result of the conversion table for velocity-loop feedback for Motor xx, Ixx04 should contain the address of the result register in the conversion table - \$003503 in the above example.

Ixx05 (Master Position Address)

To use the result of the conversion table for the master position for Motor xx, Ixx05 should contain the address of the result register in the conversion table - \$003503 in the above example.

Ixx10 and Ixx95 (Power-On Position Address and Format)

To use the MLDT for absolute power-on position for Motor xx, Ixx95 should be set to \$180000 (up to 24 bits of parallel Y-data) and Ixx10 should be set to the address of the timer register used:

Ixx10 for Acc-24E2 MLDT Timer Registers (Ixx95=\$180000)

Servo IC #	Channel 1	Channel 2	Channel 3	Channel 4
2	\$078200	\$078208	\$078210	\$078218
3	\$078300	\$078308	\$078310	\$078318
4	\$079200	\$079208	\$079210	\$079218
5	\$079300	\$079308	\$079310	\$079318
6	\$07A200	\$07A208	\$07A210	\$07A218
7	\$07A300	\$07A308	\$07A310	\$07A318
8	\$07B200	\$07B208	\$07B210	\$07B218
9	\$07B300	\$07B308	\$07B310	\$07B318

Ixx80 (Power-On Mode)

Set Ixx80 to 4 to delay the absolute power-on position read until the pulse-output frequency can be set.

Ixx81 and Ixx91 (Power-On Phase Position Address and Format)

Occasionally the MLDT is used to establish an absolute phase reference position for Turbo-PMAC-commutated motors. In this case, Ixx81 and Ixx91 are set to the same values as Ixx10 and Ixx95, respectively (see above).

Pulse Output Frequency

The pulse-output frequency is established by assigning an M-variable to the C sub-channel command register, and writing a value to that M-variable after every power-up/reset. The suggested M-variable for the Motor xx using this register is:

Mxx07->Y: {address}, 8, 16, S

where {address} is specified according to the following table:

Mxx07 for Acc-24E2A MLDT Pulse-Output Registers

Servo IC #	Channel 1	Channel 2	Channel 3	Channel 4
2	\$078204	\$07820C	\$078214	\$07821C
3	\$078304	\$07830C	\$078314	\$07831C
4	\$079204	\$07920C	\$079214	\$07921C
5	\$079304	\$07930C	\$079314	\$07931C
6	\$07A204	\$07A20C	\$07A214	\$07A21C
7	\$07A304	\$07A30C	\$07A314	\$07A31C
8	\$07B204	\$07B20C	\$07B214	\$07B21C
9	\$07B304	\$07B30C	\$07B314	\$07B31C

The frequency of the pulse output should produce a period just slightly longer than the longest expected response time for the echo pulse. For MLDTs, the response time is approximately 0.35 µsec/mm (9 µsec/inch). On an MLDT 1500 mm (~60 in) long, the longest response time is approximately 540 µsec; a recommended period between pulse outputs for this device is 600 µsec, for a frequency of 1667 Hz.

To produce the desired pulse output frequency, the following formula can be used (assuming a 16-bit M-variable definition):

$$OutputFreq(kHz) = \frac{Mxx07}{65,536} PFMCLK_Freq(kHz)$$

or:

$$Mxx07 = 65,536 * \frac{OutputFreq(kHz)}{PFMCLK_Freq(kHz)}$$

To produce a pulse output frequency of 1.667 kHz with the default PFMCLK frequency of 9.83 MHz, calculate:

$$Mxx07 = 65,536 * \frac{1.667}{9,380} \cong 11$$

To write this value to the register, a power-on PLC routine is suggested; this can also be done with on-line commands from the host computer. Sample PLC code to do this for Channel 1, using the above example value, is:

```

OPEN PLC 1 ; PLC 1 is first program to execute
CLEAR
    M107=11 ; Set pulse frequency
    CMD"$*" ; Absolute Position Read
DISABLE PLC 1 ; To not execute again
CLOSE
    
```

PMAC2/Turbo PMAC2 Conversion Table and Motor I-variables

Once the MACRO Station has been set up to process the MLDT feedback, the PMAC2 or Turbo PMAC2 can process the ongoing position feedback with its conversion table, Ix03, and Ix04 just as for any other feedback from a MACRO Station.

If the MLDT is used for absolute power-on position for the servo loop, the proper variables must be set on the PMAC2 or Turbo PMAC2:

PMAC2 Ix10 (Power-On Position Address and Format): To get the absolute position in this format for Motor x through MACRO node n (n = 0 to 15 decimal), Ix10 should be set to \$74000n, where n here is the hexadecimal representation of the node number (n = 0 to F hex).

Turbo PMAC2 Ixx10 and Ixx95 (Power-On Position Address and Format): To get the absolute position for Motor xx through MACRO node n (n = 0 to 63 decimal), Ixx10 should be set to n; in hex-format \$0000nn, where nn is the hexadecimal representation of the node number (nn = 00 to 3F hex). If node 0 is used, Ixx10 should be set to \$000100 (256 decimal). Ixx95 should be set to \$740000 to specify parallel data through a MACRO node.

If the MLDT is used for absolute power-on phase position for commutation, the proper variables must be set on the PMAC2 or Turbo PMAC2:

PMAC2 Ix81 (Power-On Phase Position Address and Format): To get the absolute phase position in this format for Motor x through MACRO node n (n = 0 to 15 decimal), Ix81 should be set to \$74000n, where n here is the hexadecimal representation of the node number (n = 0 to F hex).

Turbo PMAC2 Ixx81 and Ixx91 (Power-On Phase Position Address and Format): To get the absolute phase position for Motor xx through MACRO node n (n = 0 to 63 decimal), Ixx81 should be set to n; in hex-format \$0000nn, where nn is the hexadecimal representation of the node number (nn = 00 to 3F hex). If node 0 is used, Ixx81 should be set to \$000100 (256 decimal). Ixx91 should be set to \$740000 to specify parallel data through a MACRO node.

MLDT Feedback for UMAC-MACRO

The data from the MLDT is processed as a parallel word input at the MACRO Station and then transmitted back to the Ultralite using the traditional Servo Node. The encoder conversion table at the MACRO Station must be modified to process this data. From the Ultralite standpoint, nothing needs to be modified to read the position and velocity data.

Since the data is absolute, the data can also be sent at the Ultralite as absolute data for correct position at power-up. This is accomplished with the proper setup of MSn,MI11x at the MACRO Station, and Ix10 at the Ultralite or Ix10 and Ix95 with the Turbo Ultralite. Regardless of the type of Ultralite, retrieving the power-on-position is the same. The information must be retrieved from MACRO Station variable MSn,MI920 for each node transfer as specified by Ix10 at the Ultralite. MSn,MI920 does not need to be set up because the MACRO Station will place the power-on position the appropriate register at power-up.

MLDT Software Setup of the UMAC MACRO

When the Acc-24E2 is used for MLDT feedback in a UMAC MACRO system, there are a few MI-variables in the MACRO Station, and a few in the PMAC2 or Turbo PMAC2 driving the Station, that must be set up properly.

Station Hardware Setup I-Variables for Servo IC

MS{anynode},MI903/MI907 (PFM Clock Frequency)

Usually, the clock frequency driving the pulse-generation circuitry for all channels on the Servo IC can be left at its default value of 9.83 MHz (0.102 μ sec). Few will need to change MI903/MI907, which also controls other clock signals, from its default value of 2258.

MS{anynode},MI904/MI908 (PFM Pulse Width)

The pulse width, set by MI904/MI908 in units of PFM clock cycles must be set long enough for the MLDT to see, and long enough to contain the rising edge of the RPM start echo pulse, or the rising edge of the single DPM echo pulse. For example, if this edge can come up to 2 µsec after the start of the excitation pulse and the PMAC clock cycle is at its default of about 0.1 µsec, then I7m04 must be set at least to 20.

MS{node},MI916 (Output Format Select)

For the channel associated with this node to be used for MLDT feedback, MI916 must be set to 1 or 3 for the C sub-channel to be used for PFM-format output. On an Acc-24E2A, I7mn6 must then be set to 3 for the A and B sub-channels to be used for DAC-format output.

MS{node},MI910 (MLDT Feedback Select)

For the channel associated with this node to be used for MLDT feedback, MI910 must be set to 12. In this mode, the pulse timer is cleared on the output pulse, and latched on the echo pulse, counting in between at 117.96 MHz.

Station Conversion Table Processing I-Variables

The pulse timer for Servo IC m Channel n holds a number proportional to the time and therefore the position. This must be processed in the conversion table before it can be used by the servo loop. It is best to use the filtered parallel data conversion, a 3-line entry in the table (three consecutive MI-variables). The MI-variables for the conversion table start at MI120.

Line 1 (Method and Address): This 24-bit value (6 hex digits) should begin with a 3 (filtered parallel data) followed by the address of the timer register. The possible values for this line are shown in the following table:

Encoder Conversion Table Parallel Filtered Data Format 1st Line for Acc-24E2A Boards

Acc-24 #	Channel 1	Channel 2	Channel 3	Channel 4
1	\$30C040	\$30C048	\$30C050	\$30C058
2	\$30C060	\$30C068	\$30C070	\$30C078

Line 2 (Bits Used Mask): This 24-bit value should be set to \$07FFFF to specify the use of the low 19 bits of the 24-bit source word.

Line 3 (Max Change): This 24-bit value should be set to a value slightly greater than the maximum true velocity ever expected, expressed in timer LSBs per servo cycle. With a typical MLDT, the 117.96 MHz timer LSB represents 0.024 mm (0.00094 inches); the default servo cycle is 0.442 msec.

The result of this conversion is in the X-register of the third line. Any functions using this value should address this register. For example, if this were the first entry in the table, which starts at \$000010, the result would be in X:\$0012.

Station Motor Node I-Variables

MS{anynode}, MI10x (xth Motor Node Position Loop Feedback Address)

To use the result of the conversion table for position-loop feedback for the xth motor node, MI10x should contain the address of the result register in the conversion table - \$0012 in the previous example.

MS{anynode}, MI11x (xth Motor Node Absolute Position Address)

To use the MLDT for absolute power-on position for the xth motor node, set MI11x to \$18xxxx (up to 24 bits of parallel Y-data) from Station address xxxx, where xxxx is the address of the timer register.

MS{anynode},MI11x xth Motor Node Absolute Position

Channel 1	Channel 2	Channel 3	Channel 4
\$30C042	\$30C04A	\$30C052	\$30C05A
\$30C062	\$30C06A	\$30C072	\$30C07A

MS{anynode}, MI16x (xth Motor Node MLDT Frequency Control)

This variable establishes the frequency of the excitation pulse sent to the MLDT. Its value is written automatically to the full 24-bit C sub-channel command register for the channel assigned to this node, so the PFM circuit will create a pulse train at this frequency.

To compute the output frequency as a function of MI16x, the following formula can be used:

$$OutputFreq(kHz) = \frac{MI16x}{16,777,216} PFMCLK_Freq(kHz)$$

To compute the required value of MI16x as a function of the desired output frequency, the following formula can be used:

$$MI16x = 16,777,216 * \frac{OutputFreq(kHz)}{PFMCLK_Freq(kHz)}$$

Power-on Feedback Address for PMAC2 Ultralite

Both the Ultralite and the Turbo Ultralite can obtain absolute position at power up or upon request (#n\$*). The Ultralite must have Ix10 setup and the Turbo Ultralite needs both Ixx10 and Ixx95 setup to enable this power on position function. For power on position reads as specified in this document, MACRO firmware version 1.114 or newer is needed, the Turbo Ultralite firmware must be 1.936 or newer, and the standard Ultralite must have firmware version 1.16H or newer.

Ix10 permits an automatic read of an absolute position sensor at power-on/reset. If Ix10 is set to 0, the power-on/reset position for the motor will be considered to be 0, regardless of the type of sensor used. There are specific settings of PMAC's/PMAC2's Ix10 for each type of MACRO interface. If a Turbo Ultralite is used, Ixx95 must also be set appropriately. The Compact MACRO Station has a corresponding variable I11x for each node that must be set.

Absolute Position for Ultralite

Compact MACRO Station Feedback Type (firmware version 1.16H and above)	Ix10 (Unsigned)	Ix10 (Signed)
Acc-8D Opt 7 Resolver/Digital Converter	\$73000n	\$F3000n
Acc-8D Opt 9 Yaskawa Absolute Encoder Converter	\$72000n	\$F2000n
Acc-8D Opt 10 Sanyo Absolute Encoder Converter	\$74000n	\$F4000n
Acc-28B or Acc-28E Analog/Digital Converter	\$74000n	\$F4000n
MACRO Station Option 1C/Acc-6E A/D Converter	\$74000n	\$F4000n
MACRO Station Parallel Input	\$74000n	\$F4000n
MACRO Station MLDT Input	\$74000n	\$F4000n

'n' is the MACRO node number used for Motor x: 0, 1, 4, 5, 8, 9, C(12), or D(13).

Absolute Position for Turbo Ultralite (Ixx95=\$720000 - \$740000, \$F20000 - \$F40000)

Addresses are MACRO Node Numbers

MACRO Node Number	Ixx10 for MACRO IC 0	Ixx10 for MACRO IC 1	Ixx10 for MACRO IC 2	Ixx10 for MACRO IC 3
0	\$000100	\$000010	\$000020	\$000030
1	\$000001	\$000011	\$000021	\$000031
4	\$000004	\$000014	\$000024	\$000034
5	\$000005	\$000015	\$000025	\$000035
8	\$000008	\$000018	\$000028	\$000038
9	\$000009	\$000019	\$000029	\$000039
12	\$00000C	\$00001C	\$00002C	\$00003C
13	\$00000D	\$00001D	\$00002D	\$00003D

Compact MACRO Station Feedback Type	Ixx95 (Unsigned)	Ixx95 (Signed)
Acc-8D Opt 7 Resolver/Digital Converter	\$730000	\$F30000
Acc-8D Opt 9 Yaskawa Absolute Encoder Converter	\$720000	\$F20000
Acc-8D Opt 10 Sanyo Absolute Encoder Converter	\$740000	\$F40000
Acc-28B Analog/Digital Converter	\$740000	\$F40000
MACRO Station Option 1C/Acc-6E A/D Converter	\$740000	\$F40000
MACRO Station Parallel Input, MLDT, SSI	\$740000	\$F40000

When PMAC or PMAC2 has Ix10 set to get absolute position over MACRO, it executes a station auxiliary read command MS{node},I920 to request the absolute position from the Compact MACRO Station. The station then references its own I11x value to determine the type, format, and address of the data to be read.

MACRO Parallel Absolute Position Setup

MI111 through MI118 (MI11x) specify whether, where, and how absolute position is to be read on the Compact MACRO Station for a motor node (MI11x controls the xth motor node, usually which corresponds to Motor x on PMAC) and sent back to the Ultralite.

If MI11x is set to 0, no power-on reset absolute position value will be returned to PMAC. If MI11x is set to a value greater than 0, then when the PMAC requests the absolute position because its Ix10 and/or Ix81 values are set to obtain absolute position through MACRO (sending an auxiliary **MS{node} ,MI920** command), the Compact MACRO Station will use MI11x to determine how to read the absolute position, and report that position back to PMAC as an auxiliary response.

For an MLDT, take the output from the encoder conversion table (ECT) at the MACRO Station and process it as an absolute position because the information in the ECT is synchronized properly. Remember, the output from the encoder conversion table will reside in the X register. For example, with the following entry:

```
MS0,MI120=$30C040 ($10 of ECT)
MS0,MI121=$FFFFFF ($11 of ECT)
MS0,MI122=32      ($12 of ECT)
```

The output from the ECT will reside in X:\$12 and this will be the register to obtain the absolute data from.

MI11x consists of two parts. The low 16 bits (last four hexadecimal digits) specify the address on the MACRO Station from which the absolute position information is read. The high eight bits (first two hexadecimal digits) tell the Compact MACRO Station how to interpret the data at that address (the method).

MACRO MI11x Parallel Word Example: Signed 24-bit Absolute MLDT \$0010

HEX(\$)	D				8				0				0				1				0			
BIT	23	22	21	20	19	18	17	16	15	14	13	12	11	10	9	8	7	6	5	4	3	2	1	0
VALUE	1	1	0	1	1	0	0	0	0	0	0	0	0	0	0	0	0	0	0	1	0	0	0	0

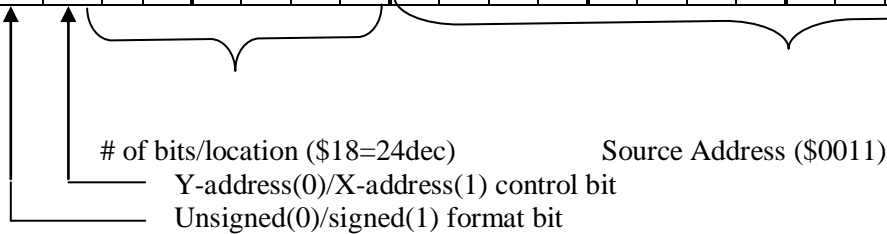

X/Y Address Bit

If bit 22 of Ix10 is 0, the PMAC looks for the parallel sensor in its Y address space. This is the standard choice, since all I/O ports map into the Y address space. If this bit is 1, PMAC looks for the parallel sensor in its X address space.

Signed/Unsigned Bit

If the most significant bit (MSB - bit 23) of MI11x is 0, the value read from the absolute sensor is treated as an unsigned quantity. If the MSB is 1, which adds \$80 to the high eight bits of MI11x, the value read from the sensor is treated as a signed, twos-complement quantity.

```
MS0,MI111=$D80010          ;read signed 24-bit absolute power on position
                           ;from X:$0010
```

Example MLDT Setup for UMAC-MACRO

```
MS0,i161=3825              ;(15*255)
Ms0,i903=2258              ;default
MS0,I904=25                ;might need to increase from factory default
MS0,I910=12
MS0,I916=3
MS0,i120=$30C040
MS0,I121=$FFFFFF          ;24-bit
MS0,I122=32               ;output at $12
MS0,i101=$12
Ms0,i111=$D80010         ;grab data from first entry of ECT X register
I110=$740000
```

Connector and Terminal Description

Direct PWM Amplifier Connector

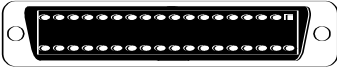
J1- PWM AMP1 (36-pin Mini-D Connector)				
Pin #	Symbol	Function	Description	Notes
1	FC0	Feedback	1 of 4 Fault Code Bits	Optional
2	FC2	Feedback	1 of 4 Fault Code Bits	Optional
3	ADC_CLK1+	Command	A/D Converter Clock	
4	ADC_STB1+	Command	A/D Converter Strobe	
5	CURRENTA+	Feedback	Phase A Actual Current Data	Serial digital
6	CURRENTB+	Feedback	Phase B Actual Current Data	Serial digital
7	AENA1+	Command	Amplifier Enable	High is enable
8	FAULT1+	Feedback	Amplifier Fault	High is fault
9	PWMATOP1+	Command	Phase A Top Cmd.	High is on command
10	PWMABOT1+	Command	Phase A Bottom Cmd.	High is on command
11	PWMBTOP1+	Command	Phase B Top Cmd.	High is on command
12	PWMBBOT1+	Command	Phase B Bottom Cmd.	High is on command
13	PWMC TOP1+	Command	Phase C Top Cmd.	High is on command
14	PWMCBOT1+	Command	Phase C Bottom Cmd.	High is on command
15	GND	Common	Reference Voltage	
16	+5V	Power	+5V Power	From controller
17	RESERVED			
18	RESERVED			
19	FC1	Feedback	1 of 4 Fault Code Bits	Optional
20	FC3	Feedback	1 of 4 Fault Code Bits	Optional
21	ADC_CLK1-	Command	A/D Converter Clock	
22	ADC_STB1-	Command	A/D Converter Strobe	
23	CURRENTA-	Feedback	Phase A Actual Current Data	Serial digital
24	CURRENTB-	Feedback	Phase B Actual Current Data	Serial digital
25	AENA1-	Command	Amplifier Enable	Low is enable
26	FAULT1-	Feedback	Amplifier Fault	Low is fault
27	PWMATOP1-	Command	Phase A Top Cmd	Low is on command
28	PWMABOT1-	Command	Phase A Bottom Cmd	Low is on command
29	PWMBTOP1-	Command	Phase B Top Cmd	Low is on command
30	PWMBBOT1-	Command	Phase B Bottom Cmd	Low is on command
31	PWMC TOP1-	Command	Phase C Top Cmd	Low is on command
32	PWMCBOT1-	Command	Phase C Bottom Cmd	Low is on command
33	GND	Common	Reference Voltage	
34	+5V	Power	+5V Power	From controller
35	RESERVED			
36	RESERVED			

A mini-D 36-pin connector for first digital amplifier command outputs and current feedbacks. This connector provides the interface to a digital amplifier for the first channel. Note that current feedback data must be in serial digital form, already converted from analog in the amplifier.

J2- PWM AMP2 (36-pin Mini-D Connector)

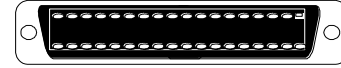

Pin #	Symbol	Function	Description	Notes
1	FC0	Feedback	1 of 4 Fault Code Bits	Optional
2	FC2	Feedback	1 of 4 Fault Code Bits	Optional
3	ADC_CLK2+	Command	A/D Converter Clock	
4	ADC_STB2+	Command	A/D Converter Strobe	
5	CURRENTA+	Feedback	Phase A Actual Current Data	Serial digital
6	CURRENTB+	Feedback	Phase B Actual Current Data	Serial digital
7	AENA2+	Command	Amplifier Enable	High is enable
8	FAULT2+	Feedback	Amplifier Fault	High is fault
9	PWMATOP2+	Command	Phase A Top Cmd	High is on command
10	PWMABOT2+	Command	Phase A Bottom Cmd	High is on command
11	PWMBTOP2+	Command	Phase B Top Cmd	High is on command
12	PWMBBOT2+	Command	Phase B Bottom Cmd	High is on command
13	PWMCTOP2+	Command	Phase C Top Cmd	High is on command
14	PWMCBOT2+	Command	Phase C Bottom Cmd	High is on command
15	GND	Common	Reference Voltage	
16	+5V	Power	+5V Power	From controller
17	RESERVED			
18	RESERVED			
19	FC1	Feedback	1 of 4 Fault Code Bits	Optional
20	FC3	Feedback	1 of 4 Fault Code Bits	Optional
21	ADC_CLK2-	Command	A/D Converter Clock	
22	ADC_STB2-	Command	A/D Converter Strobe	
23	CURRENTA-	Feedback	Phase A Actual Current Data	Serial digital
24	CURRENTB-	Feedback	Phase B Actual Current Data	Serial digital
25	AENA2-	Command	Amplifier Enable	Low is enable
26	FAULT2-	Feedback	Amplifier Fault	Low is fault
27	PWMATOP2-	Command	Phase A Top Cmd	Low is on command
28	PWMABOT2-	Command	Phase A Bottom Cmd	Low is on command
29	PWMBTOP2-	Command	Phase B Top Cmd	Low is on command
30	PWMBBOT2-	Command	Phase B Bottom Cmd	Low is on command
31	PWMCTOP2-	Command	Phase C Top Cmd	Low is on command
32	PWMCBOT2-	Command	Phase C Bottom Cmd	Low is on command
33	GND	Common	Reference Voltage	
34	+5V	Power	+5V Power	From controller
35	RESERVED			
36	RESERVED			

A mini-D 36-pin connector for first digital amplifier command outputs and current feedbacks. This connector provides the interface to a digital amplifier for the first channel. Note that current feedback data must be in serial digital form, already converted from analog in the amplifier.

Terminal Block Option for Encoders and EQU

Connector TB1 Top – Encoder 1				
Pin #	Symbol	Function	Description	Notes
1	CHA1+	Input	Encoder 1 Positive A Channel	
2	CHA1-	Input	Encoder 1 Negative A Channel	
3	CHB1+	Input	Encoder 1 Positive B Channel	
4	CHB1-	Input	Encoder 1 Negative B Channel	
5	CHC1+	Input	Encoder 1 Positive C Channel	Index channel
6	CHC1-	Input	Encoder 1 Negative C Channel	Index channel
7	ENCPWR	Output	Digital Supply	Power for encoder
8	GND	Common	Digital Reference	
9	CHU1+/DIR_1+	Input/Output	Supplemental Flag U or Direction 1+	Also direction output
10	CHV1+/DIR_1-	Input/Output	Supplemental Flag V or Direction 1-	Also direction output
11	CHW1+/PUL_1+	Input/Output	Supplemental Flag W or Pulse Output 1+	Also pulse output
12	CHT1+/PUL_1-	Input/Output	Supplemental Flag T Pulse Output 1-	Also pulse output

Connector TB2 Top – Encoder 2				
Pin #	Symbol	Function	Description	Notes
1	CHA2+	Input	Encoder 1 Positive A Channel	
2	CHA2-	Input	Encoder 1 Negative A Channel	
3	CHB2+	Input	Encoder 1 Positive B Channel	
4	CHB2-	Input	Encoder 1 Negative B Channel	
5	CHC2+	Input	Encoder 1 Positive C Channel	Index channel
6	CHC2-	Input	Encoder 1 Negative C Channel	Index channel
7	ENCPWR	Output	Digital Supply	Power for encoder
8	GND	Common	Digital Reference	
9	CHU1+/DIR_2+	Input/Output	Supplemental Flag U or Direction 2+	Also direction output
10	CHV1+/DIR_2-	Input/Output	Supplemental Flag V or Direction 2-	Also direction output
11	CHW1+/PUL_2+	Input/Output	Supplemental Flag W or Pulse Output 2+	Also pulse output
12	CHT1+/PUL_2-	Input/Output	Supplemental Flag T Pulse Output 2-	Also pulse output

Connector TB3 Top – EQU Outputs				
Pin #	Symbol	Function	Description	Notes
1	GND	Common	Reference Voltage	
2	BEQU1	Output	Compare Output 1	
3	BEQU2	Output	Compare Output 2	

DB15 Connector Option for Encoders and EQU

If the board is ordered with part number 603397-DBx, the feedback and supplemental flags use a DB15 connector. The following are the pinouts for the DB15 connectors.

Connector J1 Top - Encoder 1 / EQU

Pin #	Symbol	Function	Description	Notes
1	CHT1+/PUL_1-	I/O	Supplemental Flag T or Pulse Output 1-	Also pulse output
2	CHV1+/DIR_1-	I/O	Supplemental Flag V or Direction 1-	Also direction output
3	GND	Common	Digital Reference	
4	CHC1-	Input	Encoder 1 Negative Channel	Index channel
5	CHB1-	Input	Encoder 1 Negative B Channel	
6	CHA1-	Input	Encoder 1 Negative A Channel	
7	GND	Common	Reference Voltage	
8	BEQU2	Output	Compare Output 2	
9	CHW1+/PUL_1+	I/O	Supplemental Flag W or Pulse Output 1+	Also pulse output
10	CHU1+/DIR_1+	I/O	Supplemental Flag U or Direction 1+	Also direction output
11	ENCPWR	Output	Digital Supply	Power for encoder
12	CHC1+	Input	Encoder 1 Positive C Channel	Index channel
13	CHB1+	Input	Encoder 1 Positive B Channel	
14	CHA1+	Input	Encoder 1 Positive A Channel	
15	BEQU1	Output	Compare Output 1	

Connector J2 Top - Encoder 2 / EQU

Pin#	Symbol	Function	Description	Notes
1	CHT2+/PUL_2-	I/O	Supplemental Flag T or Pulse Output 2-	Also pulse output
2	CHV2+/DIR_2-	I/O	Supplemental Flag V or Direction 2-	Also direction output
3	GND	Common	Digital Reference	
4	CHC2-	Input	Encoder 2 Negative C Channel	Index channel
5	CHB2-	Input	Encoder 2 Negative B Channel	
6	CHA2-	Input	Encoder 2 Negative A Channel	
7	GND	Common	Reference Voltage	
8	BEQU2	Output	Compare Output 2	
9	CHW2+/PUL_2+	I/O	Supplemental Flag W or Pulse Output 2+	Also pulse output
10	CHU2+/DIR_2+	I/O	Supplemental Flag U or Direction 2+	Also direction output
11	ENCPWR	Output	Digital Supply	Power for encoder
12	CHC2+	Input	Encoder 2 Positive C Channel	Index channel
13	CHB2+	Input	Encoder 2 Positive B Channel	
14	CHA2+	Input	Encoder 2 Positive A Channel	
15	BEQU2	Output	Compare Output 2	

Flag and User Flag Terminal Block Inputs

Connector TB1 Front- Limits 1

Pin #	Symbol	Function	Description	Notes
1	USER1	Input	General Capture Flag	Sinking or sourcing
2	PLIM1	Input	Positive Limit Flag	Sinking or sourcing
3	MLIM1	Input	Negative Limit Flag	Sinking or sourcing
4	HOME1	Input	Home Flag	Sinking or sourcing
5	FLG_1_RET	Input	Return For All Flags	+V (12 to 24V) or 0V

Connector TB2 Front- Limits 2

Pin #	Symbol	Function	Description	Notes
1	USER2	Input	General Capture Flag	Sinking or sourcing
2	PLIM2	Input	Positive Limit Flag	Sinking or sourcing
3	MLIM2	Input	Negative Limit Flag	Sinking or sourcing
4	HOME2	Input	Home Flag	Sinking or sourcing
5	FLG_2_RET	Input	Return For All Flags	+V (12 to 24V) or 0V

THIS DOCUMENT IS THE CONFIDENTIAL PROPERTY OF DELTA TAU DATA SYSTEMS, INC. AND IS LOANED SUBJECT TO RETURN UPON DEMAND. TITLE TO THIS DOCUMENT IS NEVER SOLD OR TRANSFERRED FOR ANY REASON. THIS DOCUMENT IS TO BE USED ONLY PURSUANT TO WRITTEN LICENSE OR WRITTEN INSTRUCTIONS OF DELTA TAU DATA SYSTEMS, INC. ALL RIGHTS TO DESIGN AND INVENTIONS ARE RESERVED BY DELTA TAU DATA SYSTEMS, INC. POSSESSION OF THIS DOCUMENT INDICATES ACCEPTANCE OF THE ABOVE AGREEMENT.

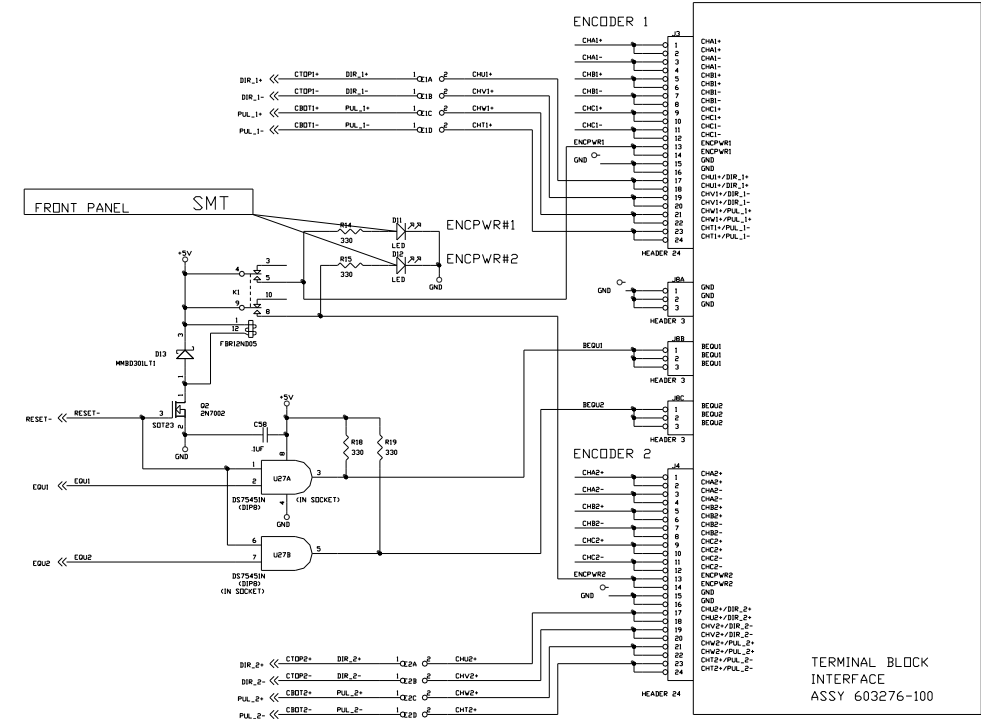
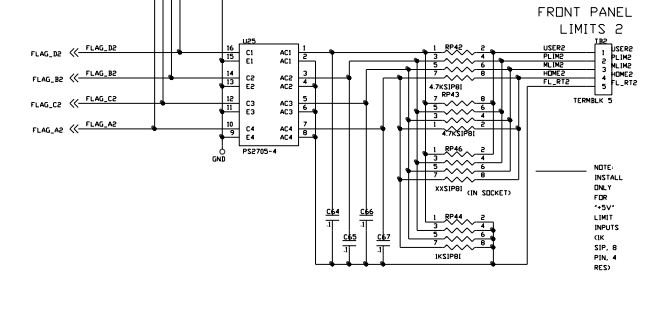
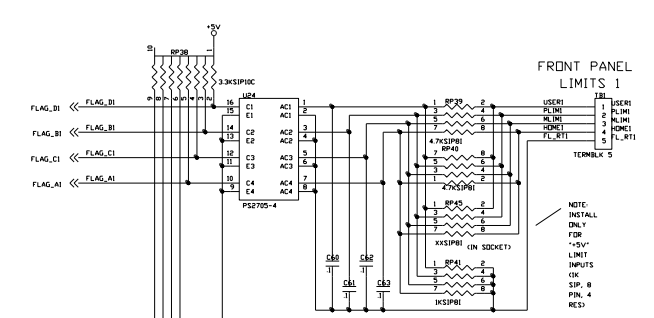
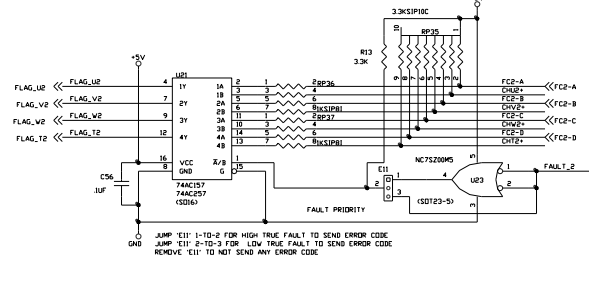
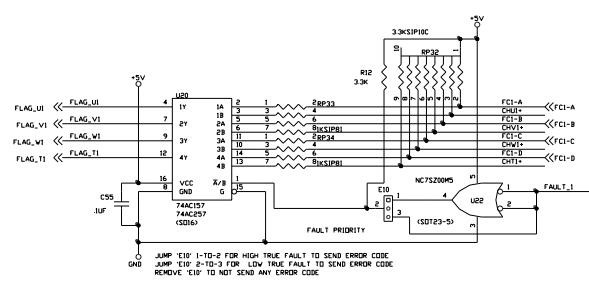
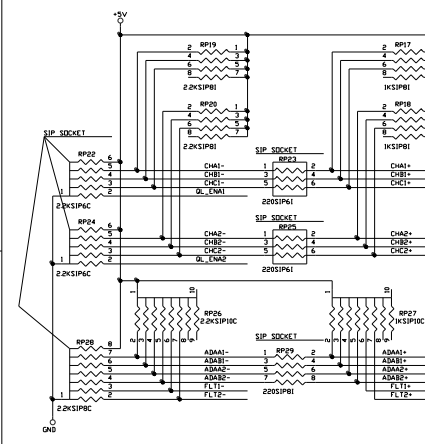
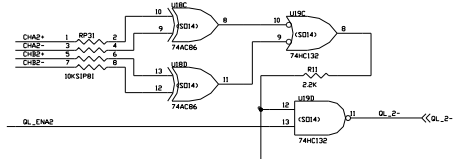
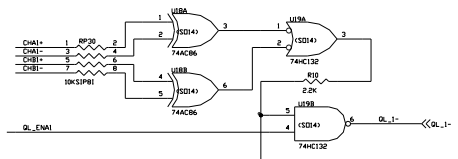
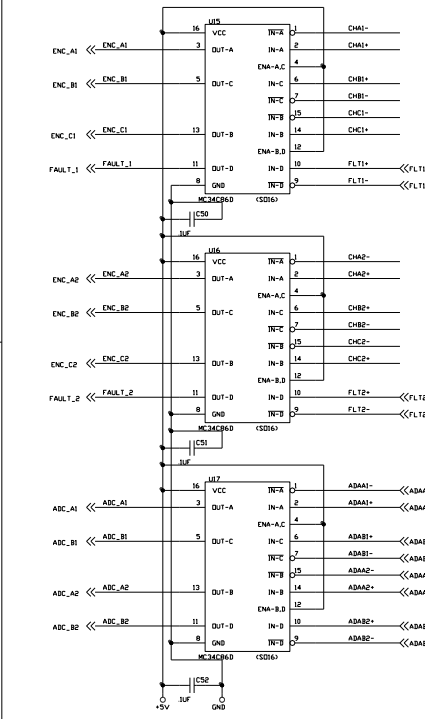

Delta Tau Data Systems, Inc
TURBO-UMAC ACC-24E2/DIGITAL FLAG+ENC SECTION
Doc # 603397-324
Date: Monday, March 10, 2003

(3397-1SH2.SCH)