

# USER MANUAL

## Accessory 36E

16 Channel 12-Bit ADC Board

3Ax-603483-xUxx

September 30, 2009



**DELTA TAU**  
Data Systems, Inc.

*NEW IDEAS IN MOTION ...*

## **Copyright Information**

© 2009 Delta Tau Data Systems, Inc. All rights reserved.

This document is furnished for the customers of Delta Tau Data Systems, Inc. Other uses are unauthorized without written permission of Delta Tau Data Systems, Inc. Information contained in this manual may be updated from time-to-time due to product improvements, etc., and may not conform in every respect to former issues.

To report errors or inconsistencies, call or email:

### **Delta Tau Data Systems, Inc. Technical Support**

Phone: (818) 717-5656

Fax: (818) 998-7807

Email: [support@deltatau.com](mailto:support@deltatau.com)

Website: <http://www.deltatau.com>

## **Operating Conditions**

All Delta Tau Data Systems, Inc. motion controller products, accessories, and amplifiers contain static sensitive components that can be damaged by incorrect handling. When installing or handling Delta Tau Data Systems, Inc. products, avoid contact with highly insulated materials. Only qualified personnel should be allowed to handle this equipment.

In the case of industrial applications, we expect our products to be protected from hazardous or conductive materials and/or environments that could cause harm to the controller by damaging components or causing electrical shorts. When our products are used in an industrial environment, install them into an industrial electrical cabinet or industrial PC to protect them from excessive or corrosive moisture, abnormal ambient temperatures, and conductive materials. If Delta Tau Data Systems, Inc. products are directly exposed to hazardous or conductive materials and/or environments, we cannot guarantee their operation.

**REVISION HISTORY**

<b>REV.</b>	<b>DESCRIPTION</b>	<b>DATE</b>	<b>CHG</b>	<b>APPVD</b>
1	ADDED CE DECLARATION	06/07/06	CP	S. FIERRO
2	ADDED SAMPLE WIRING DIAGRAM	09/08/06	CP	S. SATTARI
3	ADDED UL SEAL TO MANUAL COVER UPDATED AGENCY APPROVAL/SAFETY SECTION	09/30/09	CP	S.FIERRO



## Table of Contents

<b>INTRODUCTION .....</b>	<b>1</b>
<b>SPECIFICATIONS .....</b>	<b>3</b>
Environmental Specifications.....	3
Physical Specifications.....	3
Electrical Specifications.....	3
Agency Approval and Safety .....	4
<b>ACC-36E HARDWARE DESCRIPTION.....</b>	<b>5</b>
Connectors.....	5
<i>P1</i> .....	5
<i>J1-J4</i> .....	5
<i>P3</i> .....	5
<i>TB1</i> .....	5
Acc-36E Layout Diagram with DB15 Option.....	5
Acc-36E Layout Diagram with Terminal Block Option .....	6
E-Point Jumper.....	6
Address Select Dip Switch SW1 .....	6
<i>UMAC Turbo Switch Settings</i> .....	7
<i>MACRO Station Switch Settings</i> .....	7
Power Supply Connection TB1 .....	7
Connection to Analog Signal .....	8
Adjustment Pots .....	8
Hardware Address Limitations.....	8
<i>UMAC Card Types</i> .....	9
<i>Chip Select Addresses</i> .....	9
<i>Addressing Conflicts</i> .....	9
<i>Type A and Type B Example 1: Acc-11E and Acc-36E</i> .....	9
<i>Type A and Type B Example 2: Acc-11E and Acc-65E</i> .....	9
<b>USING ACC-36E WITH UMAC TURBO PMAC .....</b>	<b>11</b>
Enabling Turbo UMAC ADC Transfer (Automatic ADC Read Method).....	11
3U Turbo PMAC Data Acquisition Example.....	13
Acc-36E Servo Feedback Use Example for UMAC Turbo.....	13
Acc-36E Power-On Position for Turbo PMAC2.....	14
Manual ADC Read Method with UMAC Turbo .....	14
M-Variable Definitions for Manual Read Method .....	14
Data Acquisition for Manual Read Method .....	15
Reading Data through PLC Programs for Manual Read Method.....	16
<b>USING ACC-36E WITH UMAC MACRO.....</b>	<b>17</b>
Enabling MACRO ADC Transfer .....	17
<i>MI987</i> .....	17
<i>MI988</i> .....	17
<i>MI989</i> .....	17
MACRO Data Transfer Fundamentals.....	18
<i>MACRO Station I/O Node Transfer Addresses</i> .....	18
<i>PMAC2 Ultralite I/O Node Addresses</i> .....	18
<i>Turbo PMAC2 Ultralite I/O Node Addresses</i> .....	19
<b>MACRO I/O NODE DATA TRANSFER.....</b>	<b>21</b>
Automatic Transfer .....	21
<i>MI173</i> .....	21
<i>MI174</i> .....	22
<i>MI175</i> .....	22
Self Configured Data Transfer via the I/O Nodes.....	23

MI20 .....	23
MI21 through MI68 .....	23
Acc-36E Self Configured Data Acquisition Example for MACRO .....	24
Using Acc-36E for Data Acquisition for MACRO .....	25
Acc-36E Servo Feedback Use Example for MACRO .....	25
Acc-36E Configuration Example for Non Turbo and Turbo Ultralite .....	26
<i>M-Variables for the Ultralite</i> .....	26
<b>SAMPLE WIRING DIAGRAM.....</b>	<b>27</b>
<b>ACC-36E PINOUTS.....</b>	<b>28</b>
TB1 (4-pin Terminal Block).....	28
DB15 Breakout Option.....	28
<i>J1 – ADC1 through ADC4 (DB15 Connector)</i> .....	28
<i>J2 – ADC5 through ADC8 (DB15 Connector)</i> .....	29
<i>J3 – ADC9 through ADC12 (DB15 Connector)</i> .....	29
<i>J4 – ADC13 through ADC16 (DB15 Connector)</i> .....	30
Terminal Block Option (Top).....	30
Connector TB1 Top – ADC1 through ADC4 .....	30
Connector TB2 Top – ADC5 through ADC8 .....	31
Connector TB3 Top – Power Supply Outputs .....	31
Terminal Block Option (Bottom) .....	31
Connector TB1 Bottom – ADC9 through ADC12 .....	31
Connector TB2 Bottom – ADC13 through ADC16.....	32
Connector TB3 Bottom – Power Supply Outputs.....	32
JCAL 20-Pin Header Connector (for ADC Calibration at Factory Only) .....	32
<b>DECLARATION OF CONFORMITY .....</b>	<b>33</b>

## **INTRODUCTION**

---

UMAC's Accessory 36E (Acc-36E) is an analog data acquisition board capable of converting 16 analog input signals. The basic Acc-36E board is populated for 16 channels of analog input. The Analog-to-Digital Converter (ADC) units used in Acc-36E are the MAX180 monolithic devices manufactured by Maxim Integrated Products. These devices have 12-bit resolution with  $\pm 1/2$  LSB linearity specification. For more details on the ADC chips, refer to the data sheet published by the manufacturer:

Document 19-3950; Rev 0, 6/91  
Complete, 8-Channel, 12-Bit Data Acquisition Systems  
Maxim Integrated Products  
120 San Gabriel Drive  
Sunnyvale, CA 94086  
Phone: (408) 737-7600

The Acc-36E's design features make it an ideal analog data acquisition board for monitoring and collecting signals from a variety of sensors and transducers. By using simple M-variable assignments, the converted data may be used in PLC programs for monitoring and data collection purposes.

The A/D converter chips used on this accessory multiplex the data and therefore PMAC must address each channel to read them. Delta Tau has created automatic data transfers for both the 3U Turbo PMAC and the MACRO Station. This automatic method reads addresses for each channel and places the converted data automatically in memory locations accessible by the user.

For UMAC Turbo Firmware 1.936 and above, 16 channels may be read to specified UMAC memory locations automatically. These registers can be monitored using M-Variables or read into UMAC's encoder conversion table for servo feedback control.





## SPECIFICATIONS

### Environmental Specifications

Description	Specification	Notes
Operating Temperature	0°C to 45°C,	
Storage Temperature	-25°C to 70°C	
Humidity	10% to 95 % non-condensing	

### Physical Specifications

Description	Specification	Notes
Dimensions	Length: 16.256 cm (6.4 in.) Height: 10 cm (3.94 in.) Width: 2.03 cm (0.8 in.)	
Weight w/o Option 1A	190g	Front Plate included
Terminal Block Connectors	FRONT-MC1,5/12-ST3,81 FRONT-MC1,5/5-ST3,81 FRONT-MC1,5/3-ST3,81	Terminal Blocks from Phoenix Contact. UL-94V0
DB Option Connectors	DB15 Female	UL-94V0
The width is the width of the front plate. The length and height are the dimensions of the PCB.		

### Electrical Specifications

Description	Specification	Notes
ACC-36E Power Requirements	5V @ 0.15A (±10%) +15V @ 0.02A (±10%) -15V @ 0.02A (±10%)	
Fuse	125V @ 0.50A	Manufacturer: Little Fuse

**Note:**

Since the analog inputs are not optically isolated on this board, the ±15V supply to this board should not be from the same supply that is used for the UMAC's optically isolated analog outputs (DACs).

## Agency Approval and Safety

Item	Description
CE Mark	Full Compliance
EMC	EN55011 Class A Group 1 EN61000-3-2 Class A EN61000-3-3 EN61000-4-2 EN61000-4-3 EN61000-4-4 EN61000-4-5 EN61000-4-6 EN61000-4-11
Safety	EN 61010-1
UL	UL 61010-1 File E314517
cUL	CAN/CSA C22.2 No. 1010.1-92 File E314517
Flammability Class	UL 94V-0

## ACC-36E HARDWARE DESCRIPTION

### Connectors

Refer to the layout diagram in this section for the location of the connectors on the board.

#### P1

This connector is used for interface to UMAC's processor bus via the backplane of the 3U rack. The signals that are brought in through this connector are buffered on board.

#### J1-J4

Through these connectors, the analog signals are brought into Acc-36E. In addition, the +/- 12 to 15V power supplies are brought out. These power supplies may be used in situations where a separate supply unit is not available for the analog transducers.

*Note:*

The two fuses limit the current drawn to 0.5A on each supply line.

#### P3

*Caution:*

Do not use this connector.

This is a 20-pin header that is used for factory calibration.

#### TB1

This is a 4-pin terminal block, which provides the connection for power supply inputs to Acc-36E when it is used in a standalone configuration. Do not use this connector when the card is sitting on the 3U rack.

### Acc-36E Layout Diagram with DB15 Option

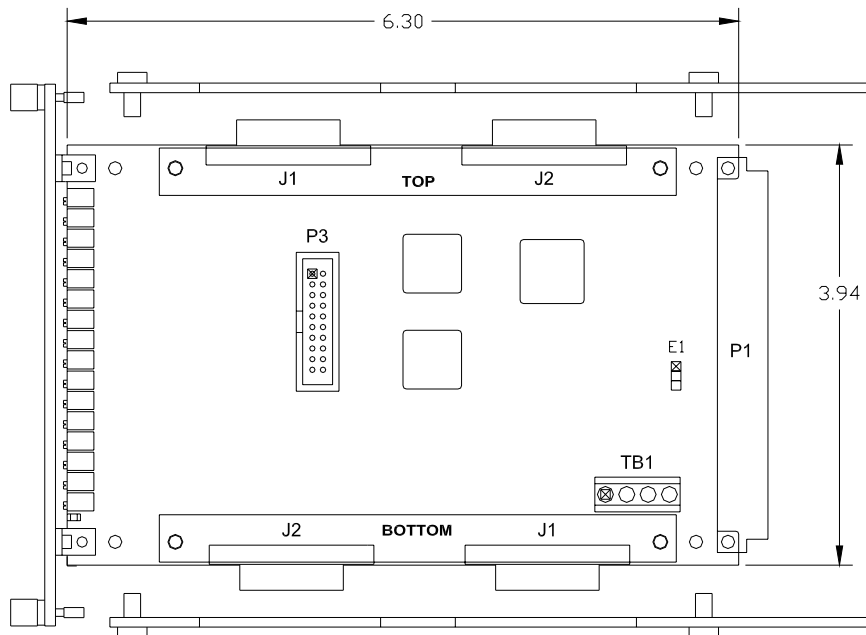

## Acc-36E Layout Diagram with Terminal Block Option

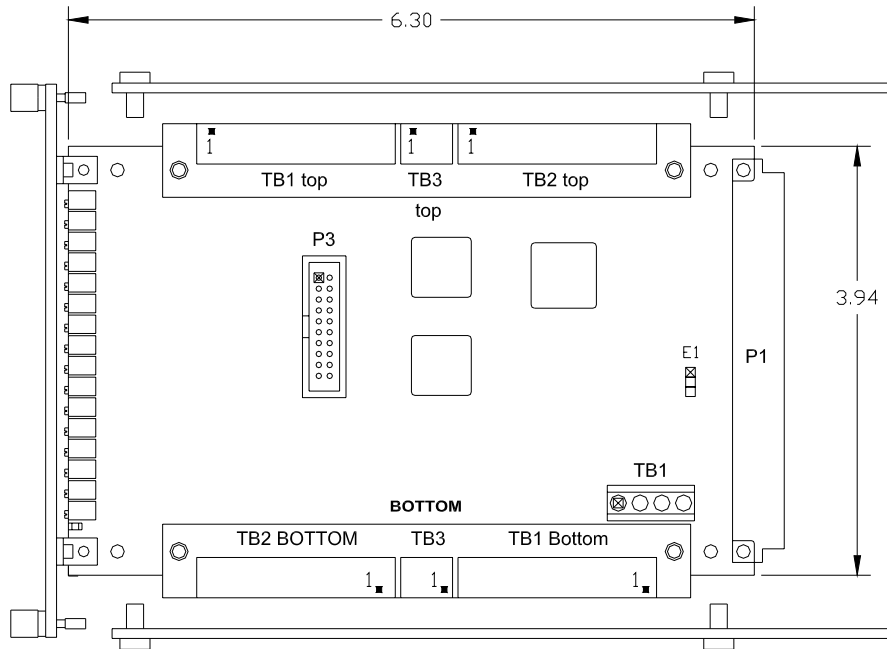

### E-Point Jumper

Jumper	Config.	Description	Settings	Default
E1	1-2	Turbo-PMAC/MACRO Select	1-2 for 3U Turbo PMAC and MACRO CPU * 2-3 for legacy MACRO CPU before 6/00	Set by factory

\* For legacy MACRO Stations (P/N 602804-100 through 602804-104)

### Address Select Dip Switch SW1

The switch two (SW1) settings will allow selection of the starting address location for the first encoder. Encoders 2 through 8 will follow in descending order from the address selected by the S2 switch. The following two tables show the dip switch settings for both the UMAC Turbo and the MACRO Station.

## UMAC Turbo Switch Settings

Chip Select	UMAC Turbo Address	DIP Switch SW1 Position					
		6	5	4	3	2	1
CS10	Y:\$78C00-03	ON	ON	ON	ON	ON	ON
	Y:\$79C00-03	ON	ON	ON	OFF	ON	ON
	Y:\$7AC00-03	ON	ON	OFF	ON	ON	ON
	Y:\$7BC00-03	ON	ON	OFF	OFF	ON	ON
CS12	Y:\$78D00-03	ON	ON	ON	ON	ON	OFF
	Y:\$79D00-03	ON	ON	ON	OFF	ON	OFF
	Y:\$7AD00-03	ON	ON	OFF	ON	ON	OFF
	Y:\$7BD00-03	ON	ON	OFF	OFF	ON	OFF
CS14	Y:\$78E00-03	ON	ON	ON	ON	OFF	ON
	Y:\$79E00-03	ON	ON	ON	OFF	OFF	ON
	Y:\$7AE00-03	ON	ON	OFF	ON	OFF	ON
	Y:\$7BE00-03	ON	ON	OFF	OFF	OFF	ON
CS16	Y:\$78F00-03	ON	ON	ON	ON	OFF	OFF
	Y:\$79F00-03	ON	ON	ON	OFF	OFF	OFF
	Y:\$7AF00-03	ON	ON	OFF	ON	OFF	OFF
	Y:\$7BF00-03	ON	ON	OFF	OFF	OFF	OFF

## MACRO Station Switch Settings

Chip Select	3U Turbo PMAC Address	DIP Switch SW1 Position					
		6	5	4	3	2	1
CS10	Y:\$8800	ON	ON	ON	ON	ON	ON
	Y:\$9800	ON	ON	ON	OFF	ON	ON
	Y:\$A800	ON	ON	OFF	ON	ON	ON
	Y:\$B800 (\$FFE0*)	ON	ON	OFF	OFF	ON	ON
CS12	Y:\$8840	ON	ON	ON	ON	ON	OFF
	Y:\$9840	ON	ON	ON	OFF	ON	OFF
	Y:\$A840	ON	ON	OFF	ON	ON	OFF
	Y:\$B840 (\$FFE8*)	ON	ON	OFF	OFF	ON	OFF
CS14	Y:\$8880	ON	ON	ON	ON	OFF	ON
	Y:\$9880	ON	ON	ON	OFF	OFF	ON
	Y:\$A880	ON	ON	OFF	ON	OFF	ON
	Y:\$B880 (\$FFF0*)	ON	ON	OFF	OFF	OFF	ON
CS16	Y:\$88C0	ON	ON	ON	ON	OFF	OFF
	Y:\$98C0	ON	ON	ON	OFF	OFF	OFF
	Y:\$A8C0	ON	ON	OFF	ON	OFF	OFF
	Y:\$B8C0	ON	ON	OFF	OFF	OFF	OFF

**Note:** The default setting is All Closed position.

## Power Supply Connection TB1

If Acc-36E is installed on the UBus backplane, both the +5V supply and the  $\pm 15V$  supplies are brought in through the bus. For standalone operations, the terminal block TB1 should be used. The power supply requirements are approximately 100mA for each of the three supplies.

## Connection to Analog Signal

---

The analog signals are brought in from J1 through J4. For a single-ended connection (using ADCx and GND), the voltage range should be from zero to 20V for unipolar signals and -10V to +10V for bipolar signals. For a differential connection (using ADCx and ADCx/), the voltage range should be between 0 to 10V for unipolar signals and -5V to 5V for bipolar signals. In addition, the  $\pm 15V$  power supply is brought out through this connector.

---

### *Note:*

The two fuses limit the current drawn to 0.5A on each supply line. For single-ended inputs, ground the complimentary signals.

---

## Adjustment Pots

---

There are 16 analog-offset adjustment pots. These 12-turn pots are located at the top edge of the printed circuit board. From left to right, R4 is for Channel 1, R8 is for channel 2, etc., and R36 is for channel 9, R40 is for channel 10, etc.

R65 and R67 pots are the voltage-reference adjustment pots for the two ADC chips (these are factory preset and should not be readjusted). In addition, R66 and R68 are the digital offset pots for the two ADC chips.

## Hardware Address Limitations

---

Some of the older UMAC I/O accessories might create a hardware address limitation relative to the newer series of UMAC high-speed I/O cards. The Acc-36E would be considered a newer high-speed I/O card. The new I/O cards have four addresses per chip select (CS10, CS12, CS14, and CS16). This enables these cards to have up to 16 different addresses. The Acc-9E, Acc-10E, Acc-11E, and Acc-12E all have one address per chip select but also have the low-byte, middle-byte, and high-byte type of addressing scheme and allow for a maximum of twelve of these I/O cards.

## UMAC Card Types

UMAC Card	Number of Addresses	Category	Maximum # of cards	Card Type
Acc-9E , Acc-10E, Acc-11E, Acc-12E	4	General IO	12	A
Acc-65E, Acc-66E, Acc-67E, Acc-68E, Acc-14E	16	General IO	16	B
Acc-28E, Acc-36E, Acc-59E	16	ADC and DAC	16	B
Acc-53E, Acc-57E, Acc-58E	16	Feedback Devices	16	B

## Chip Select Addresses

Chip Select	UMAC Turbo Type A Card	MACRO Type A Card	UMAC Turbo Type B Card	MACRO Type B Card
10	\$078C00	\$FFE0 or \$8800	\$078C00, \$079C00 \$07AC00, \$07BC00	\$8800,\$9800 \$A800,\$B800
12	\$078D00	\$FFE8 or \$8840	\$078D00, \$079D00 \$07AD00, \$07BD00	\$8840,\$9840 \$A840,\$B840
14	\$078E00	\$FFF0 or \$8880	\$078E00, \$079E00 \$07AE00, \$07EC00	\$8880,\$9880 \$A880,\$B880
16	\$078F00	\$88C0	\$078F00, \$079F00 \$07AF00, \$07BF00	\$88C0,\$98C0 \$A8C0,\$B8C0

## Addressing Conflicts

When using only the Type A or Type B UMAC cards in an application, make sure the individual cards are set to the addresses as specified in the manual to avoid potential addressing conflicts.

If using both Type A and Type B UMAC cards in the rack, be aware of the possible addressing conflicts. If using the Type A card on a particular Chip Select (CS10, CS12, CS14, or CS16) then do not use a Type B card with the same Chip Select address unless the Type B card is a general I/O type. If the Type B card is a general I/O type, then the Type B card will be the low-byte card at the Chip Select address and the Type A cards will be setup at the middle-byte and high-byte addresses.

### Type A and Type B Example 1: Acc-11E and Acc-36E

If using an Acc-11E and Acc-36E, both cards cannot use the same Chip Select because the data from both cards will be overwritten by the other card.

### Type A and Type B Example 2: Acc-11E and Acc-65E

For this example, the two cards are allowed to share the same Chip Select because the Acc-65E is a general purpose I/O Type B card. The only restriction in doing this is that the Acc-65E must be considered the low-byte addressed card and the Acc-11E must be jumpered to either the middle or high bytes (jumper E6A-E6H).





## USING ACC-36E WITH UMAC TURBO PMAC

Reading the analog data through Acc-36E is a simple procedure. There are two methods to use to read the analog inputs: write PLCs that monitor the Acc-36E board or use UMAC's automatic ADC register read feature.

The A/D converter chips used on this accessory multiplex the data and therefore, UMAC must address each channel to read them. The automatic ADC read simply addresses each ADC and copies the value into a pre-defined memory address. This copy is done every phase (110  $\mu$ sec by default) clock for two ADC channels. Manually address the ADC chip and copy the values into memory locations using the manual ADC read method.

The automatic read feature in UMAC is a simple process which allows reading the analog signals as feedback devices or for normal data acquisition by having M-variables pointing to memory locations which contain the information received by the automatic read feature. The following block diagram shows the analog data flow for servo feedback and user programs.

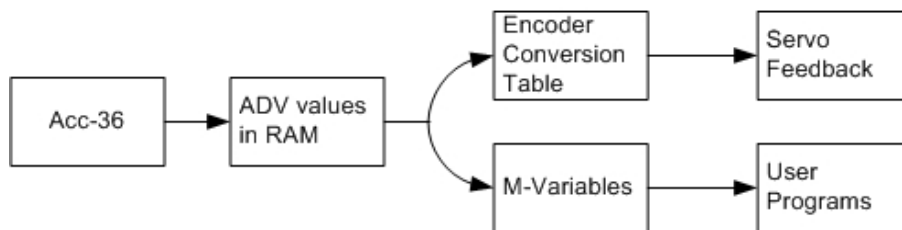

The following block diagram shows the information flow from Acc-36E to the user programs using the manual ADC read method.

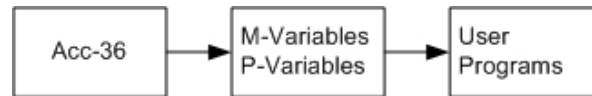

### Enabling Turbo UMAC ADC Transfer (Automatic ADC Read Method)

Just like the standard Turbo PMAC2, the Turbo UMAC allows the use of the automatic copy feature to simplify the reading of the A/D converted data. Using this method to read the data allows the use of this data for both data acquisition and closing servo loops. To enable the feature, I5060, I5061-I5076, and I5081-I5096 must be set as specified in the Turbo PMAC Software Reference manual. Up to 32 ADCs or 16 ADC pairs can be read in this fashion.

The data from the ADC returns to the PMAC memory address as a 24-bit word. The lower 12-bits contain ADC0 through ADC7 and the upper 12-bits of this word will contain the data from channels ADC8 through ADC15.

The data is copied automatically as follows:

I-Variable	Low ADC Result	High ADC Result	Acc-36E
I5061	Y:\$003400 (ADC1)	Y:\$003401 (ADC9)	1st
I5062	Y:\$003402 (ADC2)	Y:\$003403 (ADC10)	1st
I5063	Y:\$003404 (ADC3)	Y:\$003405 (ADC11)	1st
I5064	Y:\$003406 (ADC4)	Y:\$003407 (ADC12)	1st
I5065	Y:\$003408 (ADC5)	Y:\$003409 (ADC13)	1st
I5066	Y:\$00340A (ADC6)	Y:\$00340B (ADC14)	1st
I5067	Y:\$00340C (ADC7)	Y:\$00340D (ADC15)	1st
I5068	Y:\$00340E (ADC8)	Y:\$00340F (ADC16)	1st
I5069	Y:\$003410 (ADC1)	Y:\$003411 (ADC9)	2nd
I5070	Y:\$003412 (ADC2)	Y:\$003413 (ADC10)	2nd
I5071	Y:\$003414 (ADC3)	Y:\$003415 (ADC11)	2nd
I5072	Y:\$003416 (ADC4)	Y:\$003417 (ADC12)	2nd
I5073	Y:\$003418 (ADC5)	Y:\$003419 (ADC13)	2nd
I5074	Y:\$00341A (ADC6)	Y:\$00341B (ADC 14)	2nd
I5075	Y:\$00341C (ADC7)	Y:\$00341D (ADC15)	2nd
I5076	Y:\$00341E (ADC8)	Y:\$00341F (ADC16)	2nd

For the Acc-36E, I5060 controls the number of pairs of multiplexed A/D converters that are processed and de-multiplexed into individual registers. If I5060 is set to 0, none of these A/D converters is processed automatically.

If I5060 is set to a value greater than zero, it specifies the number of pairs of ADCs in the automatic processing ring. Each phase clock cycle, one pair is processed and the values copied into image registers in RAM.

I5061 through I5076 control the addresses of the multiplexed A/D converters read in the A/D ring table, as enabled by I5060. These I-variables contain offsets from the starting Turbo PMAC address \$078800 where these ADCs can reside. The base address of the Acc-36E will be defined by the SW1 setting.

I5081 through I5096 contain the convert codes written to the multiplexed A/D converters that are read in the A/D ring table, as enabled by I5060. The convert codes control which of the multiplexed ADCs at the address is to be read, and the range of the analog input for that ADC.

I5081-I5096 are 24-bit values, represented by six hexadecimal digits. Legitimate values are in the format \$00000n, where n can take any hex value from zero through F. The channels can be set as either unipolar or bipolar but can only be set in pairs. The group pairs for the channels are listed below:

Channel Pairs	ADC0 and ADC8	ADC4 and ADC12
	ADC1 and ADC9	ADC5 and ADC13
	ADC2 and ADC10	ADC6 and ADC14
	ADC3 and ADC11	ADC7 and ADC15

For the Acc-36E with a Turbo UMAC, the n value determines which of the inputs ANAI00 to ANAI07 and ANA8 to ANA15 and how it is to be converted, according to the following formulas:

n = ANAI# ; 0V to +20V unipolar input for channels n and n+8  
n = ANAI#+8 ; -10V to +10V bipolar input for channels n and n+8

For example, to read ANAI02 from Acc-36E and ANAI10 from Acc-36E option 1, both as +/-10V inputs, into the first slot in the ring, then n would be set to \$A (10), so I5081 would be set to \$00000A.

### 3U Turbo PMAC Data Acquisition Example

Set up the Turbo UMAC to read channels 0, 1, 2, 3, 8, 9, 10, and 11 as unipolar converted signals and read channels 5, 6, 7, 8, 12, 13, 14, and 15 as bipolar signals. Assume the switch settings are set for a base address of \$078C00 (\$78800 + \$400).

```

I5060=8                ;copy 8 ADC pairs
I5061=$000400         ;ADC0 and ADC8 are referenced to $078800 + $000400 ($078C00)
I5062=$000400         ;ADC1 and ADC9 are referenced to $078800 + $000400 ($078C00)
I5063=$000400         ;ADC2 and ADC10 are referenced to $078800 + $000400 ($078C00)
I5064=$000400         ;ADC3 and ADC11 are referenced to $078800 + $000400 ($078C00)
I5065=$000400         ;ADC4 and ADC12 are referenced to $078800 + $000400 ($078C00)
I5066=$000400         ;ADC5 and ADC13 are referenced to $078800 + $000400 ($078C00)
I5067=$000400         ;ADC6 and ADC14 are referenced to $078800 + $000400 ($078C00)
I5068=$000400         ;ADC7 and ADC15 are referenced to $078800 + $000400 ($078C00)
I5081=$000000         ;ADC0 unipolar ADC8 is unipolar
I5082=$000001         ;ADC1 unipolar ADC9 is unipolar
I5083=$000002         ;ADC2 unipolar ADC10 is unipolar
I5084=$000003         ;ADC3 unipolar ADC11 is unipolar
I5085=$00000C         ;ADC4 bi-polar ADC12 is bi-polar
I5086=$00000D         ;ADC5 bi-polar ADC13 is bi-polar
I5087=$00000E         ;ADC6 bi-polar ADC14 is bi-polar
I5088=$00000F         ;ADC7 bi-polar ADC15 is bi-polar

M5061->Y:$003400,12,12,u    ;channel 0 A to D as unipolar
M5062->Y:$003402,12,12,u    ;channel 1 A to D as unipolar
M5063->Y:$003404,12,12,u    ;channel 2 A to D as unipolar
M5064->Y:$003406,12,12,u    ;channel 3 A to D as unipolar
M5065->Y:$003408,12,12,s    ;channel 4 A to D as bipolar
M5066->Y:$00340A,12,12,s    ;channel 5 A to D as bipolar
M5067->Y:$00340C,12,12,s    ;channel 6 A to D as bipolar
M5068->Y:$00340E,12,12,s    ;channel 7 A to D as bipolar

M5081->Y:$003401,12,12,u    ;channel 8 A to D as unipolar
M5082->Y:$003403,12,12,u    ;channel 9 A to D as unipolar
M5083->Y:$003405,12,12,u    ;channel 10 A to D as unipolar
M5084->Y:$003407,12,12,u    ;channel 11 A to D as unipolar
M5085->Y:$003409,12,12,s    ;channel 12 A to D as bipolar
M5086->Y:$00340B,12,12,s    ;channel 13 A to D as bipolar
M5087->Y:$00340D,12,12,s    ;channel 14 A to D as bipolar
M5088->Y:$00340F,12,12,s    ;channel 15 A to D as bipolar

```

**Note:**

To start the automatic data transfer process, save and restart the 3U Turbo PMAC and then read the M-variables associated with the ADC channel.

### Acc-36E Servo Feedback Use Example for UMAC Turbo

To process the A/D information in the encoder conversion table, do the following. For this example, ADC0 will be processed from location Y:\$3400,12,12 in the ECT as a parallel unsigned entry and it is assumed that the ninth entry of the encoder conversion table (ECT) is available.

```

I8008=$203400         ;read location Y:$3400 (ECT location $3509)
I8009=$00C00C         ;read 12 bits shifted 12 bits from Y:$3400 (ECT
                      ;location $350A)

```

The axis to be used is specified by x.

```

Set Ix03=$350A        ;position feedback address
Set Ix04=$350A        ;velocity feedback address

```

## Acc-36E Power-On Position for Turbo PMAC2

As of September 27, 2000, Delta Tau firmware does not support upper 12-bit word power on position reads. However, the position register can be forced to read the appropriate power-on value using the position offset register.

```
M164->D:$00CC           ;motor 1 offset position register (1/(32*Ix08))
M264->D:$014C           ;motor 2 offset position register (1/(32*Ix08))
M364->D:$01CC           ;motor 3 offset position register (1/(32*Ix08))
M464->D:$024C           ;motor 4 offset position register (1/(32*Ix08))
M564->D:$02CC           ;motor 5 offset position register (1/(32*Ix08))
M664->D:$034C           ;motor 6 offset position register (1/(32*Ix08))
M764->D:$03CC           ;motor 7 offset position register (1/(32*Ix08))
M864->D:$044C           ;motor 8 offset position register (1/(32*Ix08))

M5061->Y:$003400,12,12,u ;channel 0 A to D as unipolar
M5062->Y:$003402,12,12,u ;channel 1 A to D as unipolar
M5063->Y:$003404,12,12,u ;channel 2 A to D as unipolar
M5064->Y:$003406,12,12,u ;channel 3 A to D as unipolar
M5065->Y:$003408,12,12,u ;channel 4 A to D as unipolar
M5066->Y:$00340A,12,12,u ;channel 5 A to D as unipolar
M5067->Y:$00340C,12,12,u ;channel 6 A to D as unipolar
M5068->Y:$00340E,12,12,u ;channel 7 A to D as unipolar
```

A PLC could be written to read the ADC into the position offset registers at power up:

```
OPEN PLC 25 CLEAR
I5111=1000*8388608/i10    ;1000 msec delay to ensure data is read properly
While (i5111>0) endwhile
M164=m5061*32*i108      ;set power on position offset to m5061 for mtr1
M264=m5062*32*i108      ;set power on position offset to m5062 for mtr2
M364=m5063*32*i108      ;set power on position offset to m5063 for mtr3
M464=m5064*32*i108      ;set power on position offset to m5064 for mtr4
M564=m5065*32*i108      ;set power on position offset to m5065 for mtr5
M664=m5066*32*i108      ;set power on position offset to m5066 for mtr6
M764=m5067*32*i108      ;set power on position offset to m5067 for mtr7
M864=m5068*32*i108      ;set power on position offset to m5068 for mtr8
Disable plc25
Close
```

## Manual ADC Read Method with UMAC Turbo

When using the manual ADC read method, address the ADC channel, and then copy the contents of the ADC register into a UMAC memory location (usually an M-variable). This can be accomplished using a PLC. If writing a PLC program to monitor the data, first define up to three M-variables for each Acc-36E board. Once the M-variables have been defined, UMAC's PLC programs may be used to initialize the analog-to-digital conversion process.

## M-Variable Definitions for Manual Read Method

Define two M-variables for an eight channel Acc-36E and three M-variables for an Acc-36E with its Option 1. A 24-bit wide unsigned integer M-variable must be pointed to the base address of the board. Next define two more M-variables each 12-bits wide and pointed to the same base address. For bipolar signals (-10 to +10V single-ended and +5V to -5V differential), these M-variables must be defined as signed integers. For unipolar signals (0 to +20V single-ended or 0 to +10V differential), define them as unsigned. For example, if the base address is at Y:\$78C00 (assuming CS10 is used), then define the three M-variables as follows:

For bipolar signals:

M1000->Y:\$78C00,24 ;M-variable for Conversion Channel Select  
M1001->Y:\$78C00,0,12,s ;M-variable for Read Data for channels 1 to 8  
M1002->Y:\$78c00,12,12,s ;M-variable for Read Data for channels 9 to 16

For unipolar signals:

M1000->Y:\$78c00,24 ;M-variable for Conversion Channel Select  
M1001->Y:\$78c00,0,12,u ;M-variable for Read Data for channels 1 to 8  
M1002->Y:\$78C00,12,12,u ;M-variable for Read Data for channels 9 to 16

**Note:**

The address Y:\$78C00 is the same for all three M-variables. In addition, the third M-variable (in this case M1002) is needed only if the Acc-36E board has Option 1 installed.

**Data Acquisition for Manual Read Method**

By writing into the ADC registers pointed to by Conversion Channel Select M-variable (M1000 in the previous example), the analog-to-digital conversion process is initialized. This process takes a few microseconds, and because of the processing speed of Turbo, a small delay may be necessary after initializing the ADC process. Afterwards, the converted data may be read through the Read Data M-variables (M101 and M102 in the above example).

The data written into the Conversion Channel Select M-variable determines both the input channel and the conversion type (unipolar Vs bipolar) as shown in the following table:

Base Address Input <sup>1</sup>	Selected Analog Input Channels <sup>2</sup>	Polarity	Single-ended Range <sup>3</sup> (volts)	Differential Range <sup>4</sup> (Volts)
0	1 and 9	Unipolar	0 to 20	0 to 10
1	2 and 10	Unipolar	0 to 20	0 to 10
2	3 and 11	Unipolar	0 to 20	0 to 10
3	4 and 12	Unipolar	0 to 20	0 to 10
4	5 and 13	Unipolar	0 to 20	0 to 10
5	6 and 14	Unipolar	0 to 20	0 to 10
6	7 and 15	Unipolar	0 to 20	0 to 10
7	8 and 16	Unipolar	0 to 20	0 to 10
8	1 and 9	Bipolar	-10 to 10	-5 to 5
9	2 and 10	Bipolar	-10 to 10	-5 to 5
10	3 and 11	Bipolar	-10 to 10	-5 to 5
11	4 and 12	Bipolar	-10 to 10	-5 to 5
12	5 and 13	Bipolar	-10 to 10	-5 to 5
13	6 and 14	Bipolar	-10 to 10	-5 to 5
14	7 and 15	Bipolar	-10 to 10	-5 to 5
15	8 and 16	Bipolar	-10 to 10	-5 to 5

<sup>1</sup>The base address is selected using CS10 - 1). The value in this column would be the value given to M100 in the above example.

<sup>2</sup> Channels 9 to 16 are applicable only when Option 1 is installed.

<sup>3</sup> For single-ended wiring, use ADCx input and AGND return.

<sup>4</sup> For differential wiring use ADCx and ADCx/ inputs.

## Reading Data through PLC Programs for Manual Read Method

For example, convert channels 4 and 10 as unipolar inputs and read channels 1 and 9 as bipolar in the PLC 10 program:

```

M100 -> Y:$78c00,24           ;M-variable for Conversion Channel Select
M101 -> Y:$78c00,0,12,u       ;M-variable for Read Data for channels 1 to 8
M102 -> Y:$78c00,12,12,u     ;M-variable for Read Data for channels 9 to 16
OPEN PLC 10
CLEAR
.
.
M100=3                        ;convert channel 4 as unipolar(also converts channel 12)
I5112=1
while (I5112>0)
endwhile
P104=M101                      ;P100 now contains converted channel 4 data
I5112=1
while (I5112>0)
M100=1                          ;convert channel 10 as unipolar (also converts
channel 2)
I5112=1
while (I5112>0)
P110=M102                      ;P100 now contains converted channel 10 data
M100=8                          ;convert channels 1 and 9 as bipolar
I5112=1
while (I5112>0)
P101=M101                      ;P101 now contains converted channel 1 data
P109=M102                      ;P109 now contains converted channel 9 data
.
.
CLOSE

```

## USING ACC-36E WITH UMAC MACRO

To use the data from the analog-to-digital converters on the Acc-36E with the MACRO system, the process must be enabled and the data transferred back using node transfer schemes. The only practical method of ADC transfer for the Acc-36E and the MACRO CPU is the automatic copy method. This method copies the ADC channels automatically from the Acc-36E to MACRO Station memory locations. The following sections will describe both of these topics in detail.

*Note:*

The MACRO CPU (602804) must have firmware version 1.15 or greater to read the ADCs from the Acc-36E. The MACRO16 CPU (603719) must have firmware version 1.202 or greater to read the ADCs from the Acc-36E.

### Enabling MACRO ADC Transfer

To enable the MACRO ADC transfer, properly set three MI variables (MI987, MI988, and MI989) at the MACRO Station. These three variables tell the MACRO Station to copy the multiplexed data to pre-set memory locations in the MACRO Station.

#### MI987

When the MI987 variable is set to 1, it will enable the automatic ADC transfer. If MI987 is set to zero, the ADC transfer will not take place.

#### MI988

The MI988 variable controls whether the optional on-board A/D converters are set up for unipolar (0 to +20V) or bipolar (-10 to +10V) inputs. MI988 consists of eight bits; each bit controls the setup of a pair of A/D converters. A value of 0 in the bit sets up the A/D converters for unipolar inputs; a value of 1 in the bits sets up the A/D converters for bipolar inputs.

The following table shows which bits of MI988 control which A/D converters:

MI988 Bit #	Hex Bit Value	First ADC	Second ADC
0	1	ANAI00	ANAI08
1	2	ANAI01	ANAI09
2	4	ANAI02	ANAI10
3	8	ANAI03	ANAI11
4	10	ANAI04	ANAI12
5	20	ANAI05	ANAI13
6	40	ANAI06	ANAI14
7	80	ANAI07	ANAI15

#### MI989

MI989 specifies the memory location to start the ADC transfer from (the address dip switch setting). For example, if the switch settings specified \$8800 as the address setting, set MI989 equal to \$8800 to properly read the ADC inputs.

**Example:** At MACRO Station 0, transfer ADC channels 0, 1, 2, 3, 8, 9, 10, and 11 as unipolar and channels 4, 5, 6, 7, 12, 13, 14, and 15 as bipolar from address setting \$8800.

```
MS0,MI987=1           ;enable ADC transfer
MS0,MI988=$F0        ;ADC channels 0,1,2,3,8,9,10, and 11 as unipolar
                       ;and channels 4,5,6,7,12,13,14, and 15 as bipolar
MS0,MI989=$8800     ;address dip switch set to $8800
```

The data from the ADC will come back to the MACRO Station memory address as a 24-bit word. The lower 12-bits will contain ADC0 through ADC7 and the upper 12-bits of this word will contain the data from channels ADC8 through ADC15. The data is copied automatically as follows:

Channel	Location
ADC0	Y:\$0200,0,12
ADC1	Y:\$0201,0,12
ADC2	Y:\$0202,0,12
ADC3	Y:\$0203,0,12
ADC4	Y:\$0204,0,12
ADC5	Y:\$0205,0,12
ADC6	Y:\$0206,0,12
ADC7	Y:\$0207,0,12

Channel	Location
ADC8	Y:\$0200,12,12
ADC9	Y:\$0201,12,12
ADC10	Y:\$0202,12,12
ADC11	Y:\$0203,12,12
ADC12	Y:\$0204,12,12
ADC13	Y:\$0205,12,12
ADC14	Y:\$0206,12,12
ADC15	Y:\$0207,12,12

## MACRO Data Transfer Fundamentals

For the Acc-36E, there are two methods to transfer the data back to the PMAC Ultralite: an automatic method using MACRO variables MI173, MI174, and MI,175 or transferring the data using the standard I/O transfer method.

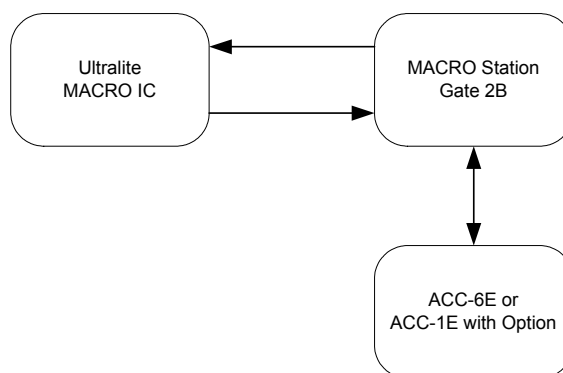

## MACRO Station I/O Node Transfer Addresses

Node(s)	Node 24-bit Transfer Addresses	Node 16-bit (upper 16 bits) Transfer Addresses
2	X:\$C0A0	X:\$C0A1, X:\$C0A2, X:\$C0A3
3	X:\$C0A4	X:\$C0A5, X:\$C0A6, X:\$C0A7
6	X:\$C0A8	X:\$C0A9, X:\$C0AA, X:\$C0AB
7	X:\$C0AC	X:\$C0AD, X:\$C0AE, X:\$C0AF
10	X:\$C0B0	X:\$C0B1, X:\$C0B2, X:\$C0B3
11	X:\$C0B4	X:\$C0B5, X:\$C0B6, X:\$C0B7

## PMAC2 Ultralite I/O Node Addresses

Node	Node 24-bit Transfer Addresses	Node 16-bit (upper 16 bits) Transfer Addresses
2	X:\$C0A0	X:\$C0A1, X:\$C0A2, X:\$C0A3
3	X:\$C0A4	X:\$C0A5, X:\$C0A6, X:\$C0A7
6	X:\$C0A8	X:\$C0A9, X:\$C0AA, X:\$C0AB
7	X:\$C0AC	X:\$C0AD, X:\$C0AE, X:\$C0AF
10	X:\$C0B0	X:\$C0B1, X:\$C0B2, X:\$C0B3
11	X:\$C0B4	X:\$C0B5, X:\$C0B6, X:\$C0B7



## Turbo PMAC2 Ultralite I/O Node Addresses

MACRO IC Node	User Node	Node 24-bit Transfer Addresses	Node 16-bit (upper 16 bits) Transfer Addresses
(IC0) 2	2	X:\$078420	X:\$078421, X:\$078422, X:\$078423
(IC0) 3	3	X:\$078424	X:\$078425, X:\$078426, X:\$078427
(IC0) 6	6	X:\$078428	X:\$078429, X:\$07842A, X:\$07842B
(IC0) 7	7	X:\$07842C	X:\$07842D, X:\$07842E, X:\$07842F
(IC0) 10	10	X:\$078430	X:\$078431, X:\$078432, X:\$078433
(IC0) 11	11	X:\$078434	X:\$078435, X:\$078436, X:\$078437
(IC1) 2	18	X:\$079420	X:\$079421, X:\$079422, X:\$079423
(IC1) 3	19	X:\$079424	X:\$079425, X:\$079426, X:\$079427
(IC1) 6	22	X:\$079428	X:\$079429, X:\$07942A, X:\$07942B
(IC1) 7	23	X:\$07942C	X:\$07942D, X:\$07942E, X:\$07942F
(IC1) 10	26	X:\$079430	X:\$079431, X:\$079432, X:\$079433
(IC1) 11	27	X:\$079434	X:\$079435, X:\$079436, X:\$079437
(IC2) 2	34	X:\$078420	X:\$07A421, X:\$07A422, X:\$07A423
(IC2) 3	35	X:\$07A424	X:\$07A425, X:\$07A426, X:\$07A427
(IC2) 6	38	X:\$07A428	X:\$07A429, X:\$07A42A, X:\$07A42B
(IC2) 7	39	X:\$07A42C	X:\$07A42D, X:\$07A42E, X:\$07A42F
(IC2) 10	42	X:\$07A430	X:\$07A431, X:\$07A432, X:\$07A433
(IC2) 11	43	X:\$07A434	X:\$07A435, X:\$07A436, X:\$07A437
(IC3) 2	50	X:\$07B420	X:\$07B421, X:\$07B422, X:\$07B423
(IC3) 3	51	X:\$07B424	X:\$07B425, X:\$07B426, X:\$07B427
(IC3) 6	54	X:\$07B428	X:\$07B429, X:\$07B42A, X:\$07B42B
(IC3) 7	55	X:\$07B42C	X:\$07B42D, X:\$07B42E, X:\$07B42F
(IC3) 10	58	X:\$07B430	X:\$07B431, X:\$07B432, X:\$07B433
(IC3) 11	59	X:\$07B434	X:\$07B435, X:\$07B436, X:\$07B437

To read the inputs from the MACRO Station of the first 24-bit I/O node address of node 2 (X:\$C0A0), point an M-variable to the Ultralite or Turbo Ultralite I/O node registers to monitor the inputs.

```
M980->X:$C0A0,0,24 ;Ultralite node2 address
M1980->X:$078420,0,24 ;Turbo Ultralite MACRO IC0 node 2 address
```

Then these M-variable definitions (M980 or M1980) can be used to monitor the inputs for either the Ultralite or Turbo Ultralite respectively.



## MACRO I/O NODE DATA TRANSFER

The data transfer from the Acc-6E to the MACRO Station transfer nodes can be achieved using three methods.

1. The first method uses MACRO I-variables to transfer the A/D data information directly to the MACRO I/O node addresses automatically.
2. The second method uses the MACRO I/O data transfer method.
3. The third method uses the encoder conversion table on the MACRO station to transfer the data for servo loop closure.

### Automatic Transfer

The automatic data transfer uses MACRO Station I-variables to send the information from the Acc-36E to the MACRO Station I/O node address. Once the information is at the MACRO Station node address, the information is used at the PMAC Ultralite. There are three MACRO Station I-variables to set up this automatic transfer:

MSn,MI173                   Up to six 12-bit transfers for A/D inputs 1-8  
 MSn,MI174                   Up to six 12-bit transfers for A/D inputs 9-16  
 MSn,MI175                   Up to four 12-bit transfers for A/D inputs 1-16, must be consecutive.

Use these MI-variables to send A/D information to the node addresses automatically, as described in the following paragraphs.

### MI173

The MI173 variable specifies the registers used in A/D transfer between one to two MACRO nodes. It transfers the lower A/Ds, three at a time, to three 16-bit nodes. The upper four bits are set to zero. The individual digits are specified as follows:

Digit #	Valid Values	Description
1	1 – 2	Specifies the number of nodes to be used.
2	0	(Reserved for future use)
3-6	\$C0A1 (Node 2), \$C0A5 (Node 3), \$C0A9 (Node 6), \$C0AD (Node 7), \$C0B1 (Node 10), \$C0B5 (Node 11)	MACRO Station X Address of MACRO I/O node first of three 16-bit registers
7	0	(Reserved for future use)
8	0	(Reserved for future use)
9-12	\$200 ... \$205	MACRO Station Y A/D Address (Bits 00 ... 11)

When this function is active, the MACRO Station copies values from the Y: Address specified in digits 9 – 12 into X: Address specified in digits 3 – 6, three at a time, up to a total of six. The move to the specified node address assumes it to be the first X: memory 16-bit node register.

#### MI73 Example:

Transfer the first six A/D converter channels (channels 1-6) using MI73.

I173 = \$20C0A1000200

A/D Channel	A/D Location	MACRO Node Address	Ultralite M-Variable	Turbo Ultralite M- Variable
ADC1	Y:\$200,0,12	X:\$C0A1,8,12	M1001->X:\$C0A1,8,12	M1001->X:\$078421,8,12
ADC2	Y:\$201,0,12	X:\$C0A2,8,12	M1002->X:\$C0A2,8,12	M1002->X:\$078422,8,12
ADC3	Y:\$202,0,12	X:\$C0A3,8,12	M1003->X:\$C0A3,8,12	M1003->X:\$078423,8,12
ADC4	Y:\$203,0,12	X:\$C0A5,8,12	M1004->X:\$C0A5,8,12	M1004->X:\$078425,8,12
ADC5	Y:\$204,0,12	X:\$C0A6,8,12	M1005->X:\$C0A6,8,12	M1005->X:\$078426,8,12
ADC6	Y:\$205,0,12	X:\$C0A7,8,12	M1006->X:\$C0A7,8,12	M1006->X:\$078427,8,12

Now the M-variables defined can be used to process the data in the PMAC Ultralite.

**MI174**

The MI174 variable specifies the registers used in A/D transfer between one to two MACRO Nodes. It will transfer the upper A/Ds, three at a time, to three 16-bit nodes. The upper four bits are set to zero. The individual digits are specified as follows:

Digit #	Valid Values	Description
1:	1 - 2	Specifies the number of nodes to be used.
2:	0	(Reserved for future use)
3-6	\$C0A1 (Node 2), \$C0A5 (Node 3), \$C0A9 (Node 6), \$C0AD (Node 7), \$C0B1 (Node 10), \$C0B5 (Node 11)	MACRO Station X Address of MACRO I/O node first of three 16-bit registers
7	0	(Reserved for future use)
8	0	(Reserved for future use)
9-12	\$200 ... \$205	MACRO Station Y A/D Address (Bits 12 ... 23)

When this function is active, the MACRO Station copies values from the Y: Address specified in digits 9 - 12 into X: Address specified in digits 3 - 6, three at a time, up to a total of six. The move to the specified node address assumes it to be the first X: memory 16-bit node register.

**MI74 Example:**

Transfer the A/D converter channels 9 through 14 using MI74.

I174 = \$20C0A9000200

A/D Channel	A/D Location	MACRO Node Address	Ultralite M- Variable	Turbo Ultralite M- Variable
ADC9	Y:\$200,12,12	X:\$C0A9,8,12	M1009->X:\$C0A9,8,12	M1009->X:\$078429,8,12
ADC10	Y:\$201,12,12	X:\$C0AA,8,12	M1010->X:\$C0AA,8,12	M1010->X:\$07842A,8,12
ADC11	Y:\$202,12,12	X:\$C0AB,8,12	M1011->X:\$C0AB,8,12	M1011->X:\$07842B,8,12
ADC12	Y:\$203,12,12	X:\$C0B1,8,12	M1012->X:\$C0B1,8,12	M1012->X:\$07842D,8,12
ADC13	Y:\$204,12,12	X:\$C0B2,8,12	M1013->X:\$C0B2,8,12	M1013->X:\$07842E,8,12
ADC14	Y:\$205,12,12	X:\$C0B3,8,12	M1014->X:\$C0B3,8,12	M1014->X:\$07842F,8,12

Now the M-variables defined can be used to process the data in the PMAC Ultralite.

**MI175**

The MI175 variable specifies the registers used in A/D transfer between one to two MACRO nodes. It transfers the upper and lower A/Ds to a 24-bit node with a maximum of two 24-bit nodes. The individual digits are specified as follows:

Digit #	Valid Values	Description
1:	1 - 2	Specifies the number of nodes to be used.
2:	0	(Reserved for future use)
3-6	\$C0A0 (Node 2), \$C0A4 (Node 3), \$C0A8 (Node 6), \$C0AC (Node 7), \$C0B0 (Node 10), \$C0B4 (Node 11)	MACRO Station X Address of MACRO I/O node 24-bit register
7	0	(Reserved for future use)
8	0	(Reserved for future use)
9-12	\$200 ... \$207	MACRO Station Y A/D Address (Bits 00 ... 23 )

When this function is active, the MACRO Station copies values from the Y: Address specified in digits 9 - 12 into X: Address specified in digits 3 - 6 one at a time, up to a total of two. The move to the specified node address assumes it to be the X: memory of a 24-bit node register.

**MI175 Example:**

Transfer the A/D converter channels 7, 8, 15, and 16 using MI75.

I175 = \$20C0A0000206

A/D Channel	A/D Location	MACRO Node Address	Ultralite M-Variable	Turbo Ultralite M-Variable
ADC7	Y:\$206,0,12	X:\$C0A0,0,12	M1007->X:\$C0A0,0,12	M1007->X:\$078420,0,12
ADC8	Y:\$207,0,12	X:\$C0A4,0,12	M1008->X:\$C0A4,12,12	M1008->X:\$078424,0,12
ADC15	Y:\$206,12,12	X:\$C0A0,12,12	M1015->X:\$C0A0,0,12	M1015->X:\$078420,12,12
ADC16	Y:\$207,12,12	X:\$C0A4,12,12	M1016->X:\$C0B1,12,12	M1016->X:\$078424,12,12

**Self Configured Data Transfer via the I/O Nodes**

The MACRO Station also transfers data back to the Ultralite from any MACRO station memory location. This function is useful for reading the 12-bit A/D converters and transferring data from either Gate1B or Gate 2B, which are not transferred automatically, or any other location for verification or troubleshooting purposes.

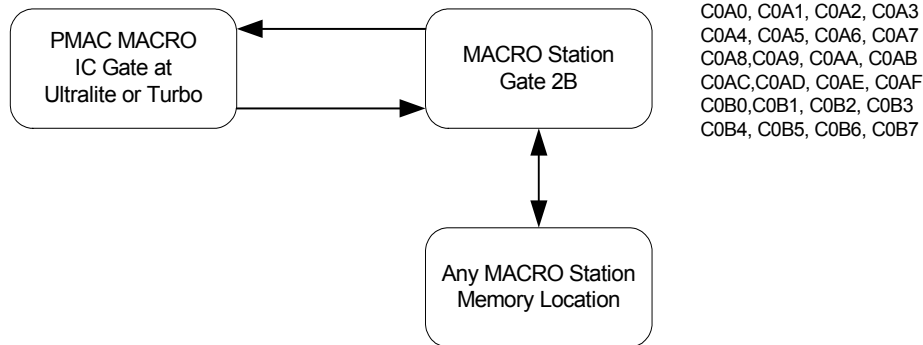

The data transfer process uses MI20 and MI21-MI68 to enable this function. Since the I/O nodes are used, MI975, MI19, and the Ultralite I/O node activation I-variables must be set to appropriate values.

**MI20**

The MI20 variable controls which of 48 possible data transfer operations are performed at the data transfer period set by MI19. MI20 is a 48-bit value; each bit controls whether the data transfer specified by one of the variables MI21 through MI68 is performed.

<b>Hex</b>	0	0	0	0	0	0	0	0	0	0	0	0	F
------------	---	---	---	---	---	---	---	---	---	---	---	---	---

```
MI20 = $1 ;transfer MI21
MI20 = $3 ;transfer MI21 and MI22
MI20 = $F ;transfer MI21, MI22, MI23, and MI24
```

**MI21 through MI68**

These variables are 48-bit addresses describing the transfer of data from the desired memory location to the MACRO Station I/O node location. This transfer can be done on a bit-by-bit basis, but typically, this data transfer process is done as a 24-bit transfer.

Hex Digit #	1	2	3	4	5	6	7	8	9	10	11	12
Contents	From Register Format Code		From Register Address				To Register Format Code		To Register Address			

The first 24 bits (six hex digits) specify the address of the register on the Compact MACRO Station from which the data is to be copied; the second 24 bits (six hex digits) specify the address on the Compact MACRO Station to which the data is to be copied. In each set of six hex digits, the last four hex digits specify the actual address. The first two digits (eight bits) specify what portion of the address is to be used.

The following table shows the 2-digit hex format codes and the portions of the address that each one selects.

Code	X or Y	Bit Width	Bit Range	Notes
\$40	Y	8	0-7	
\$48	Y	8	8-15	
\$50	Y	8	16-23	
\$54	Y	12	0-11	Lower 12-bit ADC registers
\$60	Y	12	12-23	Upper 12-bit ADC registers
\$64	Y	16	0-15	
\$6C	Y	16	8-23	16-bit MACRO Servo Node Registers
\$78	Y	24	0-23	24-bit MACRO Servo Node Registers
\$B0	X	8	0-7	
\$B8	X	8	8-15	
\$C0	X	8	16-23	
\$C4	X	12	0-11	
\$D0	X	12	12-23	
\$D4	X	16	0-15	
\$DC	X	16	8-23	16-bit MACRO I/O Node Registers
\$E8	X	24	0-23	24-bit MACRO I/O Node Registers

**Example:**

MI21=\$780200E8C0A0

copies 24-bit data from Station address Y:\$0200 to X:\$C0A0

### Acc-36E Self Configured Data Acquisition Example for MACRO

If Acc-36E is used in conjunction with I/O accessories Acc-3E, Acc-9E, Acc-10E, Acc-12E, or Acc-13E, use the three 16-bit read/write method (48-bit per node) of I/O transfer. This will free up the 24-bit I/O registers for the 16 channels of A/D. The 24-bit I/O registers could then be mapped back 12 bits at a time, and the six 24-bit registers can be used to read 12 ADCs. If more I/O registers are available, then the three 16-bit registers could be used also. If more are needed, then the ADC 16-bit registers for the current loop feedback could be used to transfer the information back to the Ultralite, when the axis node being used is not in PWM mode.

*Note:*

Remember, if there is only one master (Ultralite) in the system, then node 14 could be used for I/O transfer (two 24-bit registers and six 16-bit registers).

The following example uses two nodes with multiple reads and with address dip switch settings set for \$9800.

```
M960->X:$C0A0,0,24 ;uses node 7 24-bit register
M961->X:$C0A4,0,24 ;uses node 10 24-bit register
M72->X:$0701,0,24,S ;for non-turbo Ultralite
ms0,mi975=$CCC
ms0,mi19=4
ms0,mi20=3
ms0,mi987=1
ms0,mi988=0
ms0,mi989=$9800

#define timer M72 ;for non-turbo Ultralite
#define timer I511 ;for turbo Ultralite
open plc10 clear
cmd "ms0,I21=$780200E8C0A0" ;ADC1 and ADC9
cmd "ms0,I22=$780201E8C0A4" ;ADC2 and ADC10
timer=100*(8388608/I10) ;non-turbo Ultralite
```

```
while (timer>0) endwhile
P601=m960&$000FFF          P609=M960&$FFF000/$1000
P602=m961&$000FFF          P610=M961&$FFF000/$1000

cmd "ms0,I21=$780202E8C0A0" ;ADC3 and ADC11
cmd "ms0,I22=$780203E8C0A4" ;ADC4 and ADC12
timer=100*(8388608/I10)    ;non-turbo Ultralite
while (timer>0) endwhile
P603=M960&$000FFF          P611=M960&$FFF000/$1000
P604=M961&$000FFF          P612=M961&$FFF000/$1000

cmd "ms0,I21=$780204E8C0A0" ;ADC5 and ADC13
cmd "ms0,I22=$780205E8C0A4" ;ADC6 and ADC14
timer=100*(8388608/I10)    ;non-turbo Ultralite
while (timer>0) endwhile
P605=M960&$000FFF          P613=M960&$FFF000/$1000
P606=M961&$000FFF P614=M961&$FFF000/$1000

cmd "ms0,I21=$780206E8C0A0" ;ADC7 and ADC15
cmd "ms0,I22=$780207E8C0A4" ;ADC8 and ADC16
timer=100*(8388608/I10)
while (timer>0) endwhile
P607=M960&$000FFF          P615=M960&$FFF000/$1000
P608=M961&$000FFF          P615=M961&$FFF000/$1000

Close
```

## Using Acc-36E for Data Acquisition for MACRO

---

This example uses the I/O transfer method. This method transfers data from any MACRO station memory location to the I/O transfer node. This could be done on a bit-by-bit basis or as a 24-bit transfer. For Acc-36E, the ADC locations are found at locations Y:\$0200 through Y:\$0207. These 24-bit registers contain the information for two channels of data. The lower 12 bits contain ADC value for channel 1-8 and the upper 12-bits contains the ADC value for channels 9-16.

```
ADC1 Y:$0200,0,12          ADC9  Y:$0200,12,12
ADC2 Y:$0201,0,12          ADC10 Y:$0201,12,12
ADC3 Y:$0202,0,12          ADC11 Y:$0202,12,12
ADC4 Y:$0203,0,12          ADC12 Y:$0203,12,12
ADC5 Y:$0204,0,12          ADC13 Y:$0204,12,12
ADC6 Y:$0205,0,12          ADC14 Y:$0205,12,12
ADC7 Y:$0206,0,12          ADC15 Y:$0206,12,12
ADC8 Y:$0207,0,12          ADC16 Y:$0207,12,12
```

## Acc-36E Servo Feedback Use Example for MACRO

---

Using 4-axis servo at the MACRO Station, the fourth axis closes the servo loop on A/D converted value.

The information is sent from ADC1 at MACRO Station (Y:\$0200,0,12) to the encoder conversion table entry number four (MS0, MI123) at the station. Conversion table entry fifth (MS0, MI124) will be the mask and the result. The information is sent to the Ultralite conversion table based on MS0, MI104. MI104 should contain the address of the fifth entry of the conversion table (\$14).

```
MS0,MI987=1                ;ENABLES A/D INPUTS.
MS0,MI988=0                ;unipolar inputs
MS0,MI989=$9800           ;board address on backplane
MS0,MI123=$200200         ;feeding ANAI00 information into the end of MACRO
MS0,MI124=$000FFF         ;station conversion table with parallel Y-word data,
MS0,MI104=$14             ;no filtering conversion method. The conversion table
                           ;result will be in X:$14 of the MACRO station
```

This information will be sent to the Ultralite's encoder conversion table (fourth encoder entry) as a parallel word. By default, the position and velocity loop address should be correct.

## Acc-36E Configuration Example for Non Turbo and Turbo Ultralite

**Base Address:** \$8800

Using ADC Automatic Read Method

PMAC2 Ultralite	Turbo PMAC2 Ultralite	Description
I995=\$30	I6840=\$4030	Master and Ring Control Setup
I996=\$FCFFF	I6841=\$FCFFF	Node Activation Control
I1000=\$0033	I70=\$0033	Enables nodes for automatic copying
I1002=\$0033	I71=\$0033	Node Protocol Type
I1003=32	I78=32	Master/slave communications timeout
	I79=32	Master/master communications timeout
I1001=100	I80=100	Ring Check Period
I1004=2	I81=2	Maximum Sync Packet count
I1005=2	I82=2	Minimum Sync Packet count

### Automatic I/O Transfer Method

```

ms0,mI19=4           ;enable node transfer
ms0,mI975=$CCC      ;enable I/O channels
ms0,mI987=1         ;enable automatic copy of ADC registers
ms0,mI988=$FF       ;sets either bipolar/unipolar, this example bipolar
ms0,mI989=$8800     ;sets the copying from specified incoming ADC address
ms0,mI173 = $20C0A1000200 ;sets up the nodes 2,3 transfer to the Ultralite
ms0,mI175 = $20C0A0000206 ;sets up the nodes 10,11 transfer to the Ultralite
    
```

### M-Variables for the Ultralite

PMAC2 Ultralite	Turbo PMAC2 Ultralite	Description
M1->X:\$C0A1,8,12,S	M1->X:\$78421,8,12,S	;channel 2 node transfer -ADC1
M2->X:\$C0A2,8,12,S	M2->X:\$78422,8,12,S	;channel 2 node transfer -ADC2
M3->X:\$C0A3,8,12,S	M3->X:\$78423,8,12,S	;channel 2 node transfer -ADC3
M4->X:\$C0A5,8,12,S	M4->X:\$78425,8,12,S	;channel 3 node transfer -ADC4
M5->X:\$C0A6,8,12,S	M5->X:\$78426,8,12,S	;channel 3 node transfer -ADC5
M6->X:\$C0A7,8,12,S	M6->X:\$78427,8,12,S	;channel 3 node transfer -ADC6
M7->X:\$C0A0,0,12,S	M7->X:\$78420,0,12,S	;channel 2 node transfer -ADC7
M8->X:\$C0A4,0,12,S	M8->X:\$78424,0,12,S	;channel 3 node transfer -ADC8
M9->X:\$C0A9,8,12,S	M9->X:\$78429,8,12,S	;channel 6 node transfer -ADC9
M10->X:\$C0AA,8,12,S	M10->X:\$7842A,8,12,S	;channel 6 node transfer -ADC10
M11->X:\$C0AB,8,12,S	M11->X:\$7842B,8,12,S	;channel 6 node transfer -ADC11
M12->X:\$C0AD,8,12,S	M12->X:\$7842D,8,12,S	;channel 7 node transfer -ADC12
M13->X:\$C0AE,8,12,S	M13->X:\$7842E,8,12,S	;channel 7 node transfer -ADC13
M14->X:\$C0AF,8,12,S	M14->X:\$7842F,8,12,S	;channel 7 node transfer -ADC14
M15->X:\$C0A8,0,12,S	M15->X:\$78428,0,12,S	;channel 6 node transfer -ADC15
M16->X:\$C0AC,0,12,S	M16->X:\$7842C,0,12,S	;channel 7 node transfer -ADC16



## SAMPLE WIRING DIAGRAM

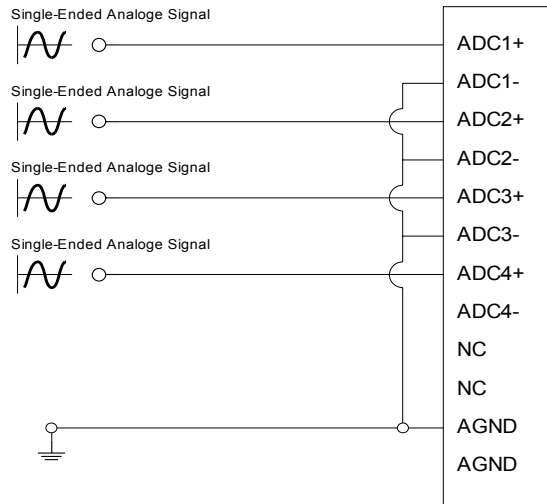
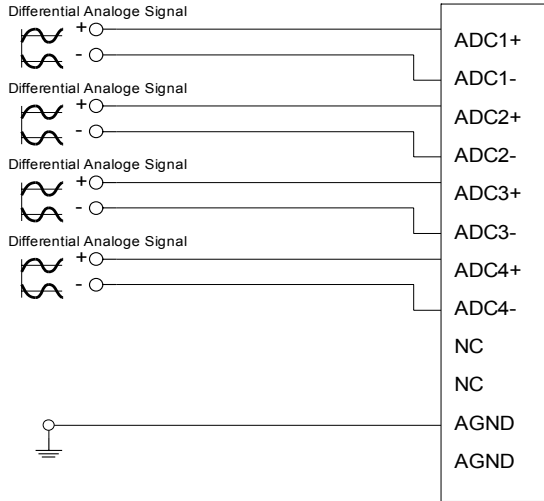

## ACC-36E PINOUTS

### TB1 (4-pin Terminal Block)

Pin #	Symbol	Function	Description
1	GND	Common	Digital Ground
2	+5V	Input	External Supply
3	+12V	Input	External Supply
4	-12V	Input	External Supply

### DB15 Breakout Option

#### J1 – ADC1 through ADC4 (DB15 Connector)

Pin #	Symbol	Function	Description
1	+ADC1	Input	+Analog Input #1
2	+ADC2	Input	+Analog Input #2
3	+ADC3	Input	+Analog Input #3
4	+ADC4	Input	+Analog Input #4
5	Open	N/A	
6	AGND	Common	Ground*
7	+12V	Output	Positive supply**
8	AGND	Common	Ground*
9	-ADC1	Input	-Analog Input #1
10	-ADC2	Input	-Analog Input #2
11	-ADC3	Input	-Analog Input #3
12	-ADC4	Input	-Analog Input #4
13	Open	N/A	
14	AGND	Common	Ground*
15	-12V	Output	Negative supply**

\* This common point is connected to the digital ground of the UMAC board.  
 \*\*The supply voltages are for output from the board to supply the sensors connected to Acc-36E. The drawn current should not exceed 0.5A.

## J2 – ADC5 through ADC8 (DB15 Connector)

Pin #	Symbol	Function	Description
1	+ADC5	Input	+Analog Input #5
2	+ADC6	Input	+Analog Input #6
3	+ADC7	Input	+Analog Input #7
4	+ADC8	Input	+Analog Input #8
5	Open	N/A	
6	AGND	Common	Ground*
7	+12V	Output	Positive supply**
8	AGND	Common	Ground*
9	-ADC5	Input	-Analog Input #5
10	-ADC6	Input	-Analog Input #6
11	-ADC7	Input	-Analog Input #7
12	-ADC8	Input	-Analog Input #8
13	Open	N/A	
14	AGND	Common	Ground*
15	-12V	Output	Negative supply**

\* This common point is connected to the digital ground of the UMAC board.  
 \*\*The supply voltages are for output from the board to supply the sensors connected to Acc-36E. The drawn current should not exceed 0.5A.

## J3 – ADC9 through ADC12 (DB15 Connector)

Pin #	Symbol	Function	Description
1	+ADC9	Input	+Analog Input #9
2	+ADC10	Input	+Analog Input #10
3	+ADC11	Input	+Analog Input #11
4	+ADC12	Input	+Analog Input #12
5	Open	N/A	
6	AGND	Common	Ground*
7	+12V	Output	Positive supply**
8	AGND	Common	Ground*
9	-ADC9	Input	-Analog Input #9
10	-ADC10	Input	-Analog Input #10
11	-ADC11	Input	-Analog Input #11
12	-ADC12	Input	-Analog Input #12
13	Open	N/A	
14	AGND	Common	Ground*
15	-12V	Output	Negative supply**

\* This common point is connected to the digital ground of the UMAC board.  
 \*\*The supply voltages are for output from the board to supply the sensors connected to Acc-36E. The drawn current should not exceed 0.5A.

## J4 – ADC13 through ADC16 (DB15 Connector)

Pin #	Symbol	Function	Description
1	+ADC13	Input	+Analog Input #13
2	+ADC14	Input	+Analog Input #14
3	+ADC15	Input	+Analog Input #15
4	+ADC16	Input	+Analog Input #16
5	Open	N/A	
6	AGND	Common	Ground*
7	+12V	Output	Positive supply**
8	AGND	Common	Ground*
9	-ADC13	Input	-Analog Input #13
10	-ADC14	Input	-Analog Input #14
11	-ADC15	Input	-Analog Input #15
12	-ADC16	Input	-Analog Input #16
13	Open	N/A	
14	AGND	Common	Ground*
15	-12V	Output	Negative supply**

\* This common point is connected to the digital ground of the UMAC board.  
 \*\*The supply voltages are for output from the board to supply the sensors connected to Acc-36E. The drawn current should not exceed 0.5 A.

## Terminal Block Option (Top)

### Connector TB1 Top – ADC1 through ADC4

Pin #	Symbol	Function	Description
1	ADC1+	Input	Analog Input #1
2	ADC1-	Input	Analog Input #1/
3	ADC2+	Input	Analog Input #2
4	ADC2-	Input	Analog Input #2/
5	ADC3+	Input	Analog Input #3
6	ADC3-	Input	Analog Input #3/
7	ADC4+	Input	Analog Input #4
8	ADC4-	Input	Analog Input #4/
9	NC	NC	
10	NC	NC	
11	AGND	Input/Output	Common reference for ADC1-ADC4
12	AGND	Input/Output	Common reference for ADC1-ADC4

### Connector TB2 Top – ADC5 through ADC8

Pin #	Symbol	Function	Description
1	ADC5+	Input	Analog Input #5
2	ADC5-	Input	Analog Input #5/
3	ADC6+	Input	Analog Input #6
4	ADC6-	Input	Analog Input #6/
5	ADC7+	Input	Analog Input #7
6	ADC7-	Input	Analog Input #7/
7	ADC8+	Input	Analog Input #8
8	ADC8-	Input	Analog Input #8/
9	NC	NC	
10	NC	NC	
11	AGND	Input/Output	Common reference for ADC5-ADC8
12	AGND	Input/Output	Common reference for ADC5-ADC8

### Connector TB3 Top – Power Supply Outputs

Pin #	Symbol	Function	Description	Notes
1	+15V	Output	+15V from UMAC power supply	Fused (1/2 A)
2	-15V	Output	-15V from UMAC power supply	Fused (1/2 A)
3	AGND	Input/Output	Common reference for ADC1-ADC16	

### Terminal Block Option (Bottom)

### Connector TB1 Bottom – ADC9 through ADC12

Pin #	Symbol	Function	Description
1	ADC9+	Input	Analog Input #9
2	ADC9-	Input	Analog Input #9/
3	ADC10+	Input	Analog Input #10
4	ADC10-	Input	Analog Input #10/
5	ADC11+	Input	Analog Input #11
6	ADC11-	Input	Analog Input #11/
7	ADC12+	Input	Analog Input #12
8	ADC12-	Input	Analog Input #12/
9	NC	NC	
10	NC	NC	
11	AGND	Input/Output	Common reference for ADC9-ADC12
12	AGND	Input/Output	Common reference for ADC9-ADC12

## Connector TB2 Bottom – ADC13 through ADC16

Pin #	Symbol	Function	Description
1	ADC13+	Input	Analog Input #13
2	ADC13-	Input	Analog Input #13/
3	ADC14+	Input	Analog Input #14
4	ADC14-	Input	Analog Input #14/
5	ADC15+	Input	Analog Input #15
6	ADC15-	Input	Analog Input #15/
7	ADC16+	Input	Analog Input #16
8	ADC16-	Input	Analog Input #16/
9	NC	NC	
10	NC	NC	
11	AGND	Input/Output	Common reference for ADC13-ADC16
12	AGND	Input/Output	Common reference for ADC13-ADC16

## Connector TB3 Bottom – Power Supply Outputs

Pin #	Symbol	Function	Description
1	NC		
2	NC		
3	NC		

## JCAL 20-Pin Header Connector (for ADC Calibration at Factory Only)

### WARNING:

This header is not pin-for-pin compatible with the PMAC2 JANA port.

Pin #	Symbol	Function	Description	Notes
1	ANAI00	Input	Analog Input 0	0-10V or +/-10V range
2	ANAI01	Input	Analog Input 1	0-10V or +/-10V range
3	ANAI02	Input	Analog Input 2	0-10V or +/-10V range
4	ANAI03	Input	Analog Input 3	0-10V or +/-10V range
5	ANAI04	Input	Analog Input 4	0-10V or +/-10V range
6	ANAI05	Input	Analog Input 5	0-10V or +/-10V range
7	ANAI06	Input	Analog Input 6	0-10V or +/-10V range
8	ANAI07	Input	Analog Input 7	0-10V or +/-10V range
9	ANAI08	Input	Analog Input 8	0-10V or +/-10V range
10	ANAI09	Input	Analog Input 9	0-10V or +/-10V range
11	ANAI10	Input□	Analog Input 10	0-10V or +/-10V range
12	ANAI11	Input	Analog Input 11	0-10V or +/-10V range
13	ANAI12	Input	Analog Input 12	0-10V or +/-10V range
14	ANAI13	Input	Analog Input 13	0-10V or +/-10V range
15	ANAI14	Input	Analog Input 14	0-10V or +/-10V range
16	ANAI15	Input	Analog Input 15	0-10V or +/-10V range
17	REF1-	Input		Reference to AGND
18	REF2-	Input		Reference to AGND
19	AGND	Common		
20	AGND	Common		

## DECLARATION OF CONFORMITY

---

**Application of Council Directive: 89/336/EEC, 72/23/EEC**

**Manufacturers Name:** Delta Tau Data Systems, Inc.

**Manufacturers Address:** 21314 Lassen Street  
Chatsworth, CA 91311  
USA

We, Delta Tau Data Systems, Inc. hereby declare that the product

**Product Name:** Accessory 36E

**Model Number:** 603483

And all of its options conforms to the following standards:

EN61326: 1997	Electrical equipment for measurement, control, and laboratory use- EMC requirements
EN55011: 1998	Limits and methods of measurements of radio disturbance characteristics of information technology equipment
EN61010-1	Electrical equipment for measurement, control, and laboratory use- Safety requirements
EN61000-3-2 :1995 A14:1998	Limits for harmonic current emissions. Criteria A
EN61000-3-3: 1995	Limitation of voltage fluctuations and flicker in low-voltage supply systems for equipment with rated current $\leq 16A$ . Criteria B.
EN61000-4-2:1995 A1: 1998	Electro Static Discharge immunity test. Criteria B
EN61000-4-3: 1995 A1: 1998	Radiated, radio-frequency, electromagnetic field immunity test. Criteria A
EN61000-4-4: 1995	Electrical fast transients/burst immunity test. Criteria B
EN61000-4-5: 1995	Surge Test. Criteria B
EN61000-4-6: 1996	Conducted immunity test. Criteria A
EN61000-4-11: 1994	Voltage dips test. Criteria B and C

**Date Issued:** 11 May 2006

**Place Issued:** Chatsworth, California USA

*Yolande Cano*

Yolande Cano  
Quality Assurance Manager

Mark of Compliance

